



# CCD 301



# Notes

- The modem is designed to be used with Xylem Cloud Services only and not as a stand-alone modem.
- Xylem reserves the right to remotely upgrade the software and configuration files in the modem. It is the Purchaser's responsibility to ensure that the modem is connected at all times to enable such upgrades.
- Xylem aims to provide mobile coverage where the modem is marketed but there is no guarantee from Xylem or obligation to ensure that cellular coverage exists in the Purchaser's location. It is the sole responsibility of the Purchaser to ensure adequate coverage in order for the modem to function properly at all times.
- The modem is delivered with a built-in SIM card. Xylem has roaming agreements with selected operators depending on geography, enabling the modem to transmit data. Xylem reserves the right to change these operators. This might have an effect on the connectivity of the modem. It is the responsibility of the Purchaser to ensure adequate connection of the modem at all times.
- It is the responsibility of the Purchaser to ensure that the modem fulfills the mobile standards in the location. This includes upgrading to a new modem if standards change over time, at Purchaser's sole cost.



---

# Table of Contents

<b>1 Introduction and Safety</b> .....	<b>2</b>
1.1 Introduction.....	2
1.2 Safety terminology and symbols.....	2
1.3 User safety.....	3
1.3.1 Power lock-out.....	4
1.3.2 Qualification of personnel.....	4
1.4 End-of-life product disposal.....	4
1.5 Spare parts.....	5
1.6 Warranty.....	5
1.7 Support.....	5
<b>2 Product Description</b> .....	<b>6</b>
2.1 Product design.....	6
2.2 Parts.....	6
2.3 Extra parts.....	7
<b>3 Installation</b> .....	<b>8</b>
3.1 Connection and configuration: Alarm management.....	8
3.1.1 Precautions.....	8
3.1.2 Requirements.....	9
3.1.3 Cables.....	9
3.1.4 Antenna.....	9
3.2 Install the equipment to the unit.....	9
3.3 Check the mobile connection.....	11
<b>4 Troubleshooting</b> .....	<b>13</b>
4.1 Symptoms and remedies.....	13
<b>5 Technical Reference</b> .....	<b>14</b>
5.1 Dimensions.....	14
5.2 Environmental requirements.....	14
5.3 Material.....	14
5.4 Approvals.....	14
5.5 Electrical data.....	14
5.6 Radio data.....	14
5.7 Terminals.....	15

# 1 Introduction and Safety

## 1.1 Introduction

### Purpose of the manual

The purpose of this manual is to provide necessary information for installation, operation, and maintenance of the unit.

### Read and keep the manual

Save this manual for future reference, and keep it readily available at the location of the unit.



### CAUTION:

Read this manual carefully before installing and using the product. Improper use of the product can cause personal injury and damage to property, and may void the warranty.

---

The equipment, and its functioning, may be impaired if used in a manner not specified by the manufacturer.

### Intended use



### WARNING:

Operating, installing, or maintaining the unit in any way that is not covered in this manual could cause death, serious personal injury, or damage to the equipment and the surroundings. This includes any modification to the equipment or use of parts not provided by Xylem. If there is a question regarding the intended use of the equipment, please contact a Xylem representative before proceeding.

---



## 1.2 Safety terminology and symbols

### About safety messages

It is extremely important that you read, understand, and follow the safety messages and regulations carefully before handling the product. They are published to help prevent these hazards:



- Personal accidents and health problems
- Damage to the product and its surroundings
- Product malfunction

## Hazard levels

Hazard level		Indication
	<b>DANGER:</b>	A hazardous situation which, if not avoided, will result in death or serious injury
	<b>WARNING:</b>	A hazardous situation which, if not avoided, could result in death or serious injury
	<b>CAUTION:</b>	A hazardous situation which, if not avoided, could result in minor or moderate injury
<b>NOTICE:</b>		Notices are used when there is a risk of equipment damage or decreased performance, but not personal injury.

## Special symbols

Some hazard categories have specific symbols, as shown in the following table.

Electrical hazard		Magnetic fields hazard	
	<b>Electrical Hazard:</b>		<b>CAUTION:</b>

## 1.3 User safety

### Introduction

All government regulations, local health and safety directives must be observed.

### Prevent danger due to electricity

All danger due to electricity must be avoided. Electrical connections must always be carried out in compliance with the following:

- The standard connections shown in the product documentation that is delivered together with the product
- All international, national, state, and local regulations. (For details, consult the regulations of your local electricity supplier.)

For more information about requirements, see sections dealing specifically with electrical connections.

### 1.3.1 Power lock-out



#### **DANGER: Electrical Hazard**

Before starting work on the unit, make sure that the unit and the control panel are isolated from the power supply and cannot be energized. This applies to the control circuit as well.



### 1.3.2 Qualification of personnel



#### **WARNING: Electrical Hazard**

Risk of electrical shock or burn. A certified electrician must supervise all electrical work. Comply with all local codes and regulations.

All work on the product must be carried out by certified electricians or Xylem authorized mechanics.

Xylem disclaims all responsibility for work done by untrained, unauthorized personnel.

## 1.4 End-of-life product disposal

Handle and dispose of all waste in compliance with local laws and regulations.

**EU and UK only: Correct disposal of this product – waste electrical and electronic equipment**

- EU: Directive 2012/19/EU on waste electrical and electronic equipment (WEEE)
- UK: SI 2013 No. 3113



WS0009973B

This marking on the product, accessories, or literature shows that the product should not be disposed of with other waste at the end of its working life.

EU and UK only: Correct disposal of batteries in this product

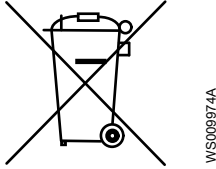

This marking on the battery, manual, or packaging shows that the batteries in this product should not be disposed of with other waste at the end of its working life. Where marked, the chemical symbols Hg, Cd, or Pb indicate that the battery contains mercury, cadmium, or lead above the reference levels in 2006/66/EC or UK SI 2008 No. 2164. If batteries are not properly disposed of, these substances can cause harm to human health or the environment.

To protect natural resources and to promote material reuse, please separate batteries from other types of waste and recycle them through your local, free battery return system.

## 1.5 Spare parts



### CAUTION:

Only use the manufacturer's original spare parts to replace any worn or faulty components. The use of unsuitable spare parts may cause malfunctions, damage, and injuries as well as void the warranty.

## 1.6 Warranty

For information about warranty, see the sales contract.

## 1.7 Support

Xylem only supports products that have been tested and approved. Xylem does not support unapproved equipment.

# 2 Product Description

## 2.1 Product design

CCD 301 is a wireless unit that is used in pumping stations.

The unit sends data over the General Pack Radio Service (GPRS), 2G, or 3G network.

The unit allows remote monitoring and data collection from any location.

## 2.2 Parts

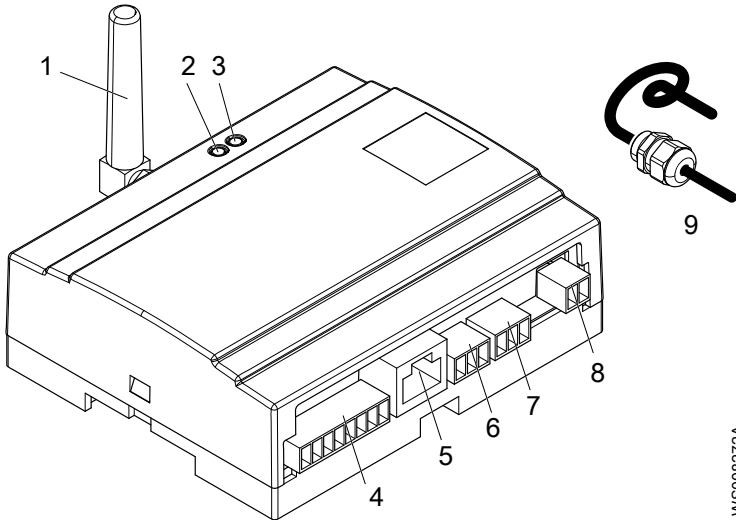

Figure 1: CCD301, part number 803 49 00

Part	Description
1	Antenna, see <a href="#">Extra parts</a> on page 7
2	LED, red or green, network signal strength
3	LED, yellow, connection to the cloud service
4	Digital and analog input
5	Ethernet terminal
6	RS-232 terminals
7	RS-485 terminals
8	Input power
9	Cables for different connections, see <a href="#">Extra parts</a> on page 7

## 2.3 Extra parts

Part number	Item	Description
803 98 00	RS-232 communication and power cable	Connects the FGC pump controller to the unit
815 20 00	RS-485 communication cable	Connects the SRC 311 pump drive or a data cable splitter to the unit
83 84 43	RS-485 data cable splitter	Connects two SRC 311 pump drives to the unit
83 84 45	1 m cable with RJ45 connectors	Connects a SRC 311 pump drive to the data cable splitter
83 84 46	3 m cable with RJ45 connectors	Connects a SRC 311 pump drive to the data cable splitter
85 01 12	Small GSM antenna	Connects to the SubMiniature version A (SMA) connector
40 50 12 75	External GSM antenna with 2.5 m cable	Connects to the SubMiniature version A (SMA) connector
40 50 12 16	Power supply	24 VDC, 3.2 A

EN

# 3 Installation

## 3.1 Connection and configuration: Alarm management

### 3.1.1 Precautions

Before starting work, make sure that the safety instructions have been read and understood.



---

**DANGER: Electrical Hazard**

Before starting work on the unit, make sure that the unit and the control panel are isolated from the power supply and cannot be energized. This applies to the control circuit as well.

**DANGER: Electrical Hazard**

All electrical equipment must be grounded (earthed). Test the ground (earth) lead to verify that it is connected correctly and that the path to ground is continuous.

**WARNING: Electrical Hazard**

Risk of electrical shock or burn. A certified electrician must supervise all electrical work. Comply with all local codes and regulations.

**WARNING: Electrical Hazard**

There is a risk of electrical shock or explosion if the electrical connections are not correctly carried out, or if there is fault or damage on the product. Visually inspect equipment for damaged cables, cracked casings or other signs of damage. Make sure that electrical connections have been correctly made.

**CAUTION: Electrical Hazard**

Prevent cables from becoming sharply bent or damaged.

---

### 3.1.2 Requirements

These requirements apply for the electrical installation:

- The mains voltage and frequency must agree with the specifications for the product.
- Circuit breakers must be installed between the main voltage line and this unit.
- All fuses and circuit breakers must have the proper rating, and comply with local regulations.
- The cables must be in accordance with the local rules and regulations.
- If the power cable is jerked loose, then the ground (earth) conductor must be the last conductor to come loose from its terminal. Make sure that the ground (earth) conductor is longer than the phase conductors at both ends of the cable.

### 3.1.3 Cables

These requirements apply for cable installation:

- The cables must be in good condition, not have any sharp bends, and not be pinched.
- The sheathing must not be damaged and must not have indentations or be embossed at the cable entry.
- The minimum bending radius must not be below the accepted value.
- The cables must have the appropriate temperature rating.

### 3.1.4 Antenna

These requirements apply for the antenna installation:

- The antenna must be kept away from the radio or EMC source.
- The antenna cables must be kept away from other electronics.
- The length of the antenna cables must be as short as possible.
- The antenna cables can run the full length but they must not be bent to avoid interference and crosstalk.

## 3.2 Install the equipment to the unit

- Before installation of the unit, record the serial number or take a picture of the serial number of the unit. After installation, the serial number is not seen.
- The unit must not be installed over 2 m (6.56 ft) height from the ground.

#### 1. Attach the antenna.

For more information about the antenna, see [Antenna](#) on page 15.

The antenna is an extra part, see [Extra parts](#) on page 7.

#### 2. Install the unit on a DIN rail.

#### 3. Select one of the following steps to connect a device to the unit.

For more information about the devices that connect with the unit, go to the support site at [support.avensor.cloud](http://support.avensor.cloud).

- Connect the RS-232 cable from the pump controller to the terminals.

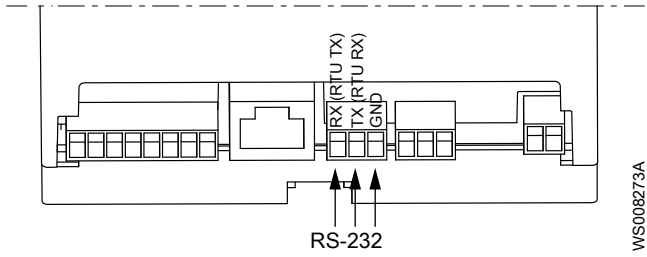

Signal lead color	Unit terminal
White	Rx, RTU Tx
Green	Tx, RTU Rx
Yellow	Ground (earth)

- Connect the RS-485 cable from the pump drive to the terminals.

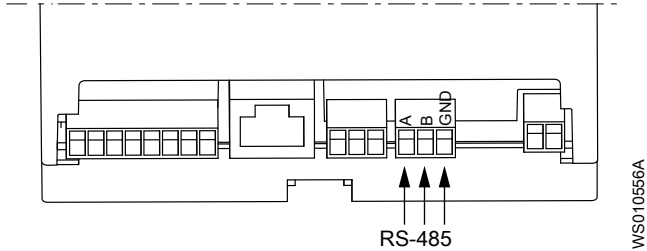

Signal lead color	Unit terminal
Brown	A
White or brown	B
White or green	Ground (earth)

- Connect the two signals leads from the digital switch to the terminals.

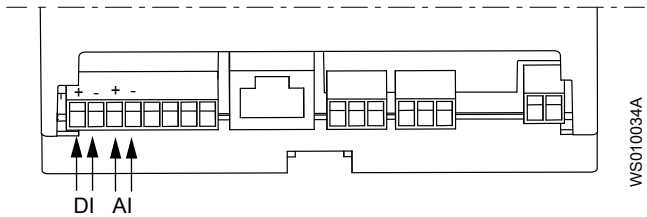

Digital input is active when supplied with 24 VDC and it is inactive when open.

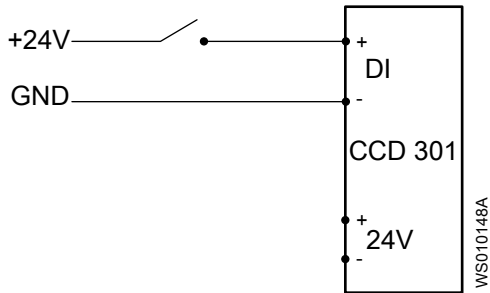

- Connect the 4-20 mA analog input device to the terminals.

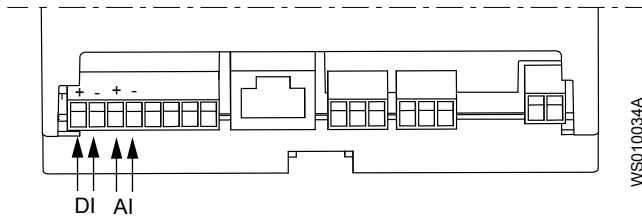

For more information about the terminals, see [Terminals](#) on page 15.

4. Connect the power leads to the power input terminals.

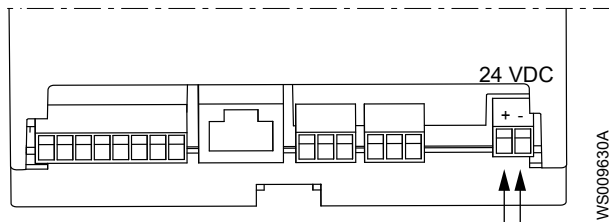

5. Turn on the power of the equipment and if necessary, the separate power supply.
6. Configure the connected devices.

For more information, go to the support site at [support.avensor.cloud](http://support.avensor.cloud).

### 3.3 Check the mobile connection

The unit is turned on.

1. Check the network signal strength.

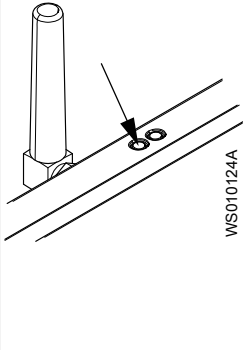
LED	State	Description
	Blinks red	Searches for the network
	Solid green	Good signal strength
	Solid red	Medium signal strength
	Unlit	Low signal strength

- If the signal strength is too low, move the external antenna to another position.  
For more information, see .
- Check the connection to the cloud service.

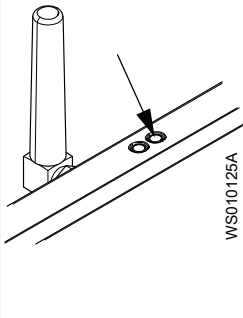
LED	State	Connection
	Blinks yellow every 5 s	Yes
	Solid yellow	No
	Unlit	No

The connection procedure takes maximum 15 minutes.

The unit must not be disconnected during the connection procedure.

# 4 Troubleshooting

## 4.1 Symptoms and remedies

Symptom	Remedy
The digital input alarm triggers without cause.	<ul style="list-style-type: none"><li>• When an active digital switch is used, make sure that the unit and the active digital switch have common ground (earth).</li><li>• Make sure that the input voltage is more than 15 V.</li></ul>
The connection to the cloud service is slow.	<ul style="list-style-type: none"><li>• Make sure that the equipment is not disconnected from the cloud service. Repeated disconnections can make the reconnection slow.</li><li>• Check the signal strength and install or move the external antenna to improve the signal strength.</li></ul>

# 5 Technical Reference

## 5.1 Dimensions

EN

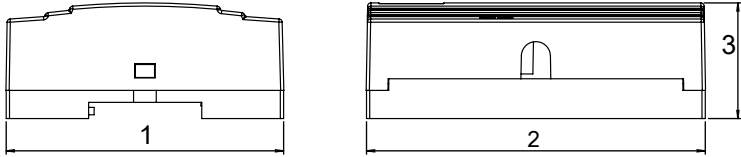

WS008257A

Part	Dimension
1	86 mm (3.4 in)
2	105 mm (4.1 in)
3	36 mm (1.4 in)

## 5.2 Environmental requirements

Feature	Value
Operating temperature	-30°C to +70°C (-22°F to +158°F)
Storage temperature	-10°C to +75°C (14°F to +167°F)
Operating humidity	95% relative humidity, non-condensing

## 5.3 Material

- UL94 V-0. Plastic materials

## 5.4 Approvals

- CE

## 5.5 Electrical data

Feature	Description
Supply voltage	24 VDC
Current	Maximum 200 mA at 24 VDC
Degree of protection of enclosure	IP20
Internal battery	Li-ion, 2600 mAh

## 5.6 Radio data

The unit has a radio modem that supports the following bands:

Network	Frequency, band
3G	850/800, 900, 1900, and 2100
2G	850, 900, 1800, and 1900

## 5.7 Terminals

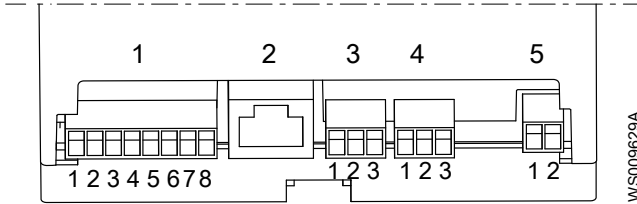

Connector number	Name	Terminal number	Description
1	Digital input	1	Digital input Active = 24VDC Inactive = 0VDC or not connected
		2	Ground (earth)
	Analog input	3	4-20 mA
		4	Ground (earth)
	Not used	5	Not used
		6	Not used
		7	Not used
		8	Not used
2	Ethernet	-	RJ45
3	RS-232	1	Rx, RTU Tx
		2	Tx, RTU Rx
		3	Ground (earth)
4	RS-485 with 120 ohm termination resistor	1	A
		2	B
		3	Ground (earth)
5	Input power	1	24VDC
		2	Ground (earth)

### Antenna

- SMA connector
- Maximum 10 m (32.8 ft) cable

# Xylem |'zīləm|

- 1) The tissue in plants that brings water upward from the roots;
- 2) a leading global water technology company.

We're a global team unified in a common purpose: creating advanced technology solutions to the world's water challenges. Developing new technologies that will improve the way water is used, conserved, and re-used in the future is central to our work. Our products and services move, treat, analyze, monitor and return water to the environment, in public utility, industrial, residential and commercial building services settings. Xylem also provides a leading portfolio of smart metering, network technologies and advanced analytics solutions for water, electric and gas utilities. In more than 150 countries, we have strong, long-standing relationships with customers who know us for our powerful combination of leading product brands and applications expertise with a strong focus on developing comprehensive, sustainable solutions.

For more information on how Xylem can help you, go to [www.xylem.com](http://www.xylem.com)



Visit our Web site for the latest version of this document and more information  
The original instruction is in English.  
All non-English instructions are translations of the original instruction.  
© 2013 Xylem Inc.