



FGC 313/323

Table of Contents

1	Introduction and Safety.....	3
1.1	Introduction.....	3
1.2	Safety terminology and symbols.....	3
1.3	User safety.....	4
1.3.1	Power lock-out.....	4
1.3.2	Qualification of personnel.....	4
1.4	End of life product disposal.....	4
1.5	Spare parts.....	5
1.6	Warranty.....	5
1.7	Support.....	5
2	Transportation and Storage.....	6
2.1	Examine the delivery.....	6
2.2	Storage guidelines.....	6
3	Product Description.....	7
3.1	Product design.....	7
3.2	Parts.....	7
3.3	Approvals and standards.....	7
4	System Description.....	8
4.1	Overview.....	8
5	Function Description.....	9
5.1	Level monitoring.....	9
5.1.1	Pressure sensor.....	9
5.1.2	Open Bell.....	10
5.1.3	Float switches.....	10
6	Mechanical Installation.....	11
6.1	Install the unit.....	11
7	Electrical Installation.....	13
7.1	Precautions.....	13
7.2	External switch.....	13
7.3	Do not install in an explosive zone.....	13
7.4	Connect the power supply.....	13
7.5	Connect the digital input signals.....	15
7.6	Connect an analog level sensor.....	15
7.7	Connect a general output signal.....	16
7.8	Connect a power supply for external devices.....	17
8	System Setup.....	18
8.1	Select a language.....	18
8.2	Configure the stop condition of the pump.....	18
8.3	Configure pressure or pneumatic level sensors.....	18
8.4	Configure an ultrasonic level sensor.....	19
8.5	Configure the maximum motor current.....	19
8.6	Configure the start, stop, and high levels.....	19

8.7	Configure the high level switch.....	20
8.8	Configure the pump stop delay.....	20
8.9	Configure alternation between pumps.....	20
8.10	Configure the number of pumps to run simultaneously.....	20
8.11	Configure a maintenance run schedule.....	21
8.12	Configure the maximum runtime for a pump.....	21
8.13	Configure a service interval.....	21
8.14	Configure the general input.....	22
8.15	Configure the general output.....	22
8.16	Configure the alarm delays.....	22
8.17	Configure the internal alarm buzzer.....	23
8.18	Restore to the default settings.....	23
9	Operation.....	24
9.1	Push-button functions.....	24
9.2	View the run time data.....	25
9.3	Reset the run time data.....	25
9.4	Control a pump manually.....	26
9.5	Control a pump automatically.....	26
9.6	Acknowledge an alarm.....	26
9.7	Prevent a personnel alarm.....	26
9.8	View the alarm log.....	26
9.9	Clear the alarm log from inactive alarms.....	27
9.10	View or reset the hours since the last service.....	27
10	Maintenance.....	28
10.1	Preventive maintenance.....	28
11	Troubleshooting.....	29
11.1	Common problems.....	29
11.2	View status of the input and output signals.....	29
11.3	Invert the input signals.....	30
11.4	Signal Positions.....	30
11.5	Run the diagnostic programs.....	31
12	Technical Reference.....	32
12.1	Dimensions.....	32
12.2	Environmental requirements.....	32
12.3	IP rating.....	32
12.4	Electrical data.....	32
12.5	Terminals and connectors.....	33
12.6	Menu chart.....	35
12.7	Operation menus.....	36
12.8	Setup menus.....	37
12.9	Service menus.....	42
12.10	Alarm descriptions.....	47
12.11	LED descriptions.....	49

1 Introduction and Safety

1.1 Introduction

Purpose of the manual

The purpose of this manual is to provide necessary information for installation, operation, and maintenance of the unit.

Read and keep the manual

Save this manual for future reference, and keep it readily available at the location of the unit.



CAUTION:

Read this manual carefully before installing and using the product. Improper use of the product can cause personal injury and damage to property, and may void the warranty.

The equipment, and its functioning, may be impaired if used in a manner not specified by the manufacturer.

Intended use



WARNING:

Operating, installing, or maintaining the unit in any way that is not covered in this manual could cause death, serious personal injury, or damage to the equipment and the surroundings. This includes any modification to the equipment or use of parts not provided by Xylem. If there is a question regarding the intended use of the equipment, please contact a Xylem representative before proceeding.

1.2 Safety terminology and symbols

About safety messages

It is extremely important that you read, understand, and follow the safety messages and regulations carefully before handling the product. They are published to help prevent these hazards:

- Personal accidents and health problems
- Damage to the product and its surroundings
- Product malfunction



Hazard levels

Hazard level	Indication
DANGER:	A hazardous situation which, if not avoided, will result in death or serious injury
WARNING:	A hazardous situation which, if not avoided, could result in death or serious injury
CAUTION:	A hazardous situation which, if not avoided, could result in minor or moderate injury

Hazard level	Indication
NOTICE:	Notices are used when there is a risk of equipment damage or decreased performance, but not personal injury.

Special symbols

Some hazard categories have specific symbols, as shown in the following table.

Electrical hazard	Magnetic fields hazard
 Electrical Hazard:	 CAUTION:

1.3 User safety

Introduction

All government regulations, local health and safety directives must be observed.

Prevent danger due to electricity

All danger due to electricity must be avoided. Electrical connections must always be carried out in compliance with the following:

- The standard connections shown in the product documentation that is delivered together with the product
- All international, national, state, and local regulations. (For details, consult the regulations of your local electricity supplier.)

For more information about requirements, see sections dealing specifically with electrical connections.

1.3.1 Power lock-out



DANGER: Electrical Hazard

Before starting work on the unit, make sure that the unit and the control panel are isolated from the power supply and cannot be energized. This applies to the control circuit as well.



1.3.2 Qualification of personnel



WARNING: Electrical Hazard

Risk of electrical shock or burn. A certified electrician must supervise all electrical work. Comply with all local codes and regulations.

All work on the product must be carried out by certified electricians or Xylem authorized mechanics.

Xylem disclaims all responsibility for work done by untrained, unauthorized personnel.

1.4 End of life product disposal

Handle and dispose of all waste in compliance with local laws and regulations.

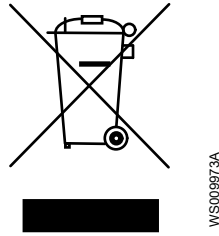
EU only: Correct disposal of this product — WEEE Directive on waste electrical and electronic equipment

This marking on the product, accessories or literature indicates that the product should not be disposed of with other waste at the end of its working life.

To prevent possible harm to the environment or human health from uncontrolled waste disposal, please separate these items from other types of waste and recycle them responsibly to promote the sustainable reuse of material resources.

Waste from electrical and electronic equipment can be returned to the producer or distributor.

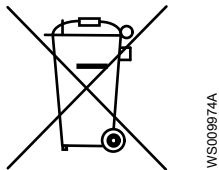
EU only: Correct disposal of batteries in this product

This marking on the battery, manual or packaging indicates that the batteries in this product should not be disposed of with other waste at the end of its working life. Where marked, the chemical symbols Hg, Cd or Pb indicate that the battery contains mercury, cadmium or lead above the reference levels in Directive 2006/66/EC. If batteries are not properly disposed of, these substances can cause harm to human health or the environment.

To protect natural resources and to promote material re-use, please separate batteries from other types of waste and recycle them through your local, free battery return system.

1.5 Spare parts

**CAUTION:**

Only use the manufacturer's original spare parts to replace any worn or faulty components. The use of unsuitable spare parts may cause malfunctions, damage, and injuries as well as void the warranty.

1.6 Warranty

For information about warranty, see the sales contract.

1.7 Support

Xylem only supports products that have been tested and approved. Xylem does not support unapproved equipment.

2 Transportation and Storage

2.1 Examine the delivery

Inspect the package

1. Inspect the package for damaged or missing items upon delivery.
2. Note any damaged or missing items on the receipt and freight bill.
3. File a claim with the shipping company if anything is out of order.
If the product has been picked up at a distributor, make a claim directly to the distributor.

Inspect the product

1. Remove packing materials from the product.
Dispose of all packing materials in accordance with local regulations.
2. Inspect the product to determine if any parts are damaged or missing.
3. If applicable, unfasten the product by removing any screws, bolts, or straps.
For your personal safety, be careful when you handle nails and straps.
4. Contact your sales representative if anything is out of order.

2.2 Storage guidelines

Storage location

The product must be stored in a covered and dry location free from heat, dirt, and vibrations.

NOTICE:

Protect the product against humidity, heat sources, and mechanical damage.

NOTICE:

Do not place heavy weights on the packed product.

3 Product Description

3.1 Product design

The controller is designed for small wastewater pumping stations, with one or two pumps, and different types of level sensors. It monitors the level of a wastewater well, and controls and operates the pumps.

Expansion modules

- Battery backup module
- Communication module

3.2 Parts

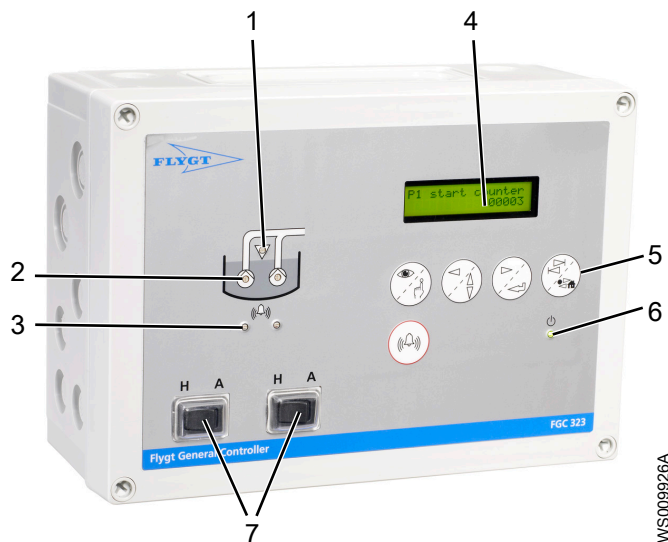

1. High level LED
2. Pump status LED
3. Pump failure LED
4. Screen
5. Push-buttons
6. Power-on LED
7. Hand-Off-Auto switch

3.3 Approvals and standards

- CE approval
- EMC standard: EN61000-6-3
- EMC standard: EN61000-6-2
- LVD standard: EN61010-1

4 System Description

4.1 Overview

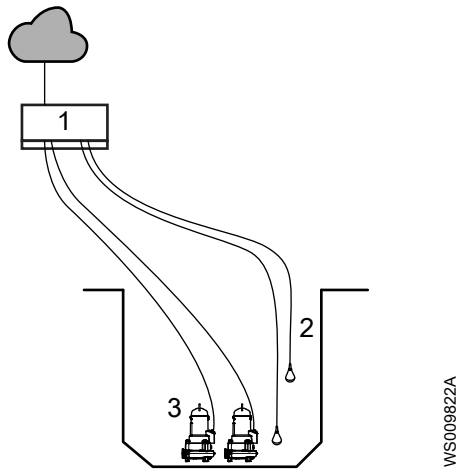

Parts

Number	Part	Description
1	Controller	The controller monitors and controls the operation of the pumps.
2	Level device	<ul style="list-style-type: none"> • Analog sensors • Open Bell • Ultrasonic sensor • Float switches
3	Pumps	The controller monitors and controls one or two pumps. Pumps that are rated for currents greater than 12A need external contactors.

5 Function Description

5.1 Level monitoring

Levels are monitored with float switches or with float switches and an analog sensor.

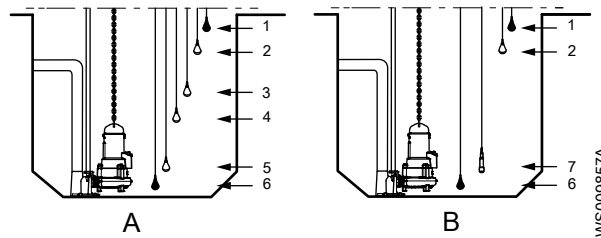

Number	A: Float switches	B: Float switches and analog sensor	
1	Overflow	Overflow	This float switch is optional. The overflow or the low-level float switch is connected to the general-purpose digital input. The input must be configured for its intended purpose.
2	High level	High level	This float switch is optional.
3	Start level, standby pump	–	This float switch is used in a two-pump station.
4	Start level, duty pump	–	This float switch is always used when the controller is configured for float switches.
5	Stop level	–	This float switch is always used when the controller is configured for float switches.
6	Low level	Low level	This float switch is optional. The overflow or the low-level float switch is connected to the general-purpose digital input. The input must be configured for its intended purpose.
7	–	Analog sensor	A pressure sensor or an Open Bell sensor is used when the controller is configured for an analog sensor.

5.1.1 Pressure sensor

The sensor measures the hydrostatic pressure and transforms it into a 4–20 mA electric signal. The controller converts the signal to a water level that is expressed in meters or feet.

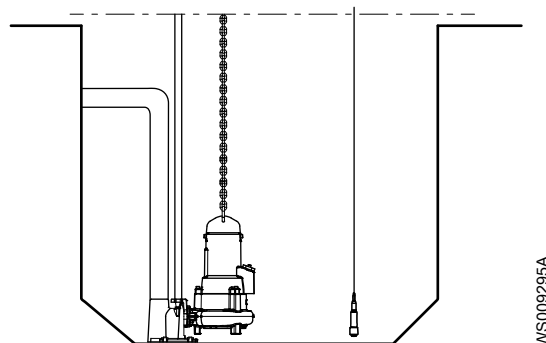

5.1.2 Open Bell

The Open Bell level sensor connects to a pneumatic sensor in the controller. The range is 0 m to 5.1 m (16.7 ft). The lowest water level must sink below the Open Bell level sensor in each pump cycle.

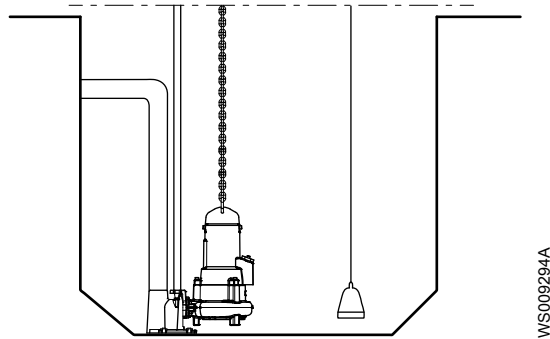

WS009294A

5.1.3 Float switches

A float switch provides an input signal at a configured start or stop level. A maximum of five switches is possible.

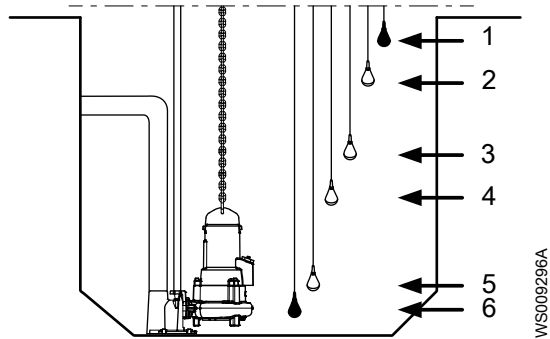

WS009296A

1. Overflow
2. High level
3. Start level, standby pump
4. Start level, duty pump
5. Stop level
6. Low level

6 Mechanical Installation

6.1 Install the unit

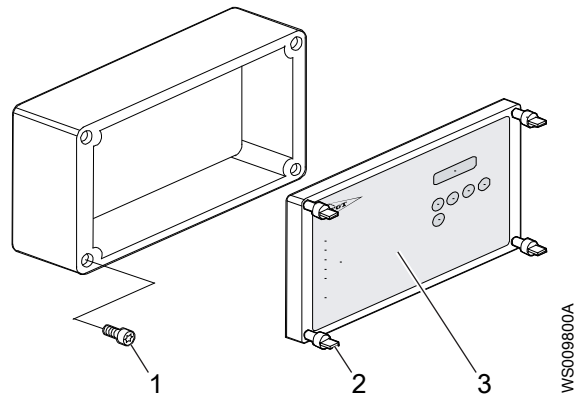

1. 4-mm screw
2. Front lid screw
3. Front lid

1. Unscrew the four screws that hold the front lid in position.
2. Remove the front lid.
3. Mark the location of the four holes according to the hole layout.

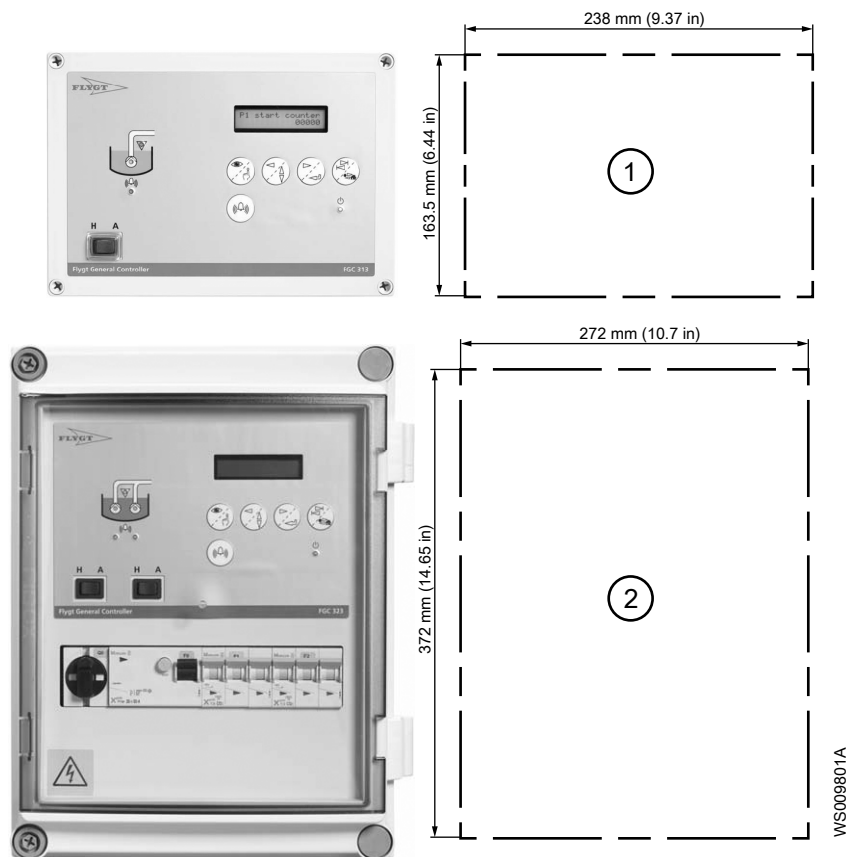

1. Hole layout for a small enclosure
2. Hole layout for a large enclosure
4. Drill the screw holes with a 2-mm drill.
5. Attach the unit against the wall with four 4-mm screws.

6. Place the front lid on the unit.
7. Attach the four screws that hold the front lid in position.

7 Electrical Installation

7.1 Precautions

Before starting work, make sure that the safety instructions have been read and understood.



DANGER: Electrical Hazard

Before starting work on the unit, make sure that the unit and the control panel are isolated from the power supply and cannot be energized. This applies to the control circuit as well.



DANGER: Electrical Hazard

All electrical equipment must be grounded (earthed). Test the ground (earth) lead to verify that it is connected correctly and that the path to ground is continuous.



WARNING: Electrical Hazard

Risk of electrical shock or burn. A certified electrician must supervise all electrical work. Comply with all local codes and regulations.



WARNING: Electrical Hazard

There is a risk of electrical shock or explosion if the electrical connections are not correctly carried out, or if there is fault or damage on the product. Visually inspect equipment for damaged cables, cracked casings or other signs of damage. Make sure that electrical connections have been correctly made.



CAUTION: Electrical Hazard

Prevent cables from becoming sharply bent or damaged.

7.2 External switch

This product cannot be used as an emergency stop device.

An external switch or circuit breaker must be provided near the installation to enable the pump to be isolated from the power supply.

7.3 Do not install in an explosive zone

NOTICE:

Do not use this unit in environments that may contain flammable/explosive or chemically aggressive gases or powders.

7.4 Connect the power supply

1. Select one of the steps to connect the power supply to the terminals:

FGC 300 (Type must match supplying grid).	Terminal connections
Small Range: 3x200-460 VAC+N+PE, 50-60 Hz (3-phase with neutral and protective earth)	<p style="text-align: right;">WS009802A</p>
Small Range: 1x120-240 VAC+N+PE, 50-60 Hz (Single-phase with neutral and protective earth)	<p style="text-align: right;">WS009803A</p>
Small Range: 3x230 VAC+PE, 50-60 Hz (3-phase with protective earth, no neutral)	<p style="text-align: right;">WS009804A</p>

2. Select one of the steps to connect the pump with the terminals and contactor:

FGC 300 (Type must match supplying grid).	Terminal and contactor connections
<ul style="list-style-type: none"> Small Range: 3x200-460 VAC+N+PE, 50-60 Hz (3-phase with neutral and protective earth) Small Range: 3x230 VAC+PE, 50-60 Hz (3-phase with protective earth, no neutral) 	<p style="text-align: right;">WS009805A</p>
Small Range: 1x120-240 VAC+N+PE, 50-60 Hz (Single-phase with neutral and protective earth)	<p style="text-align: right;">WS009806A</p>

7.5 Connect the digital input signals

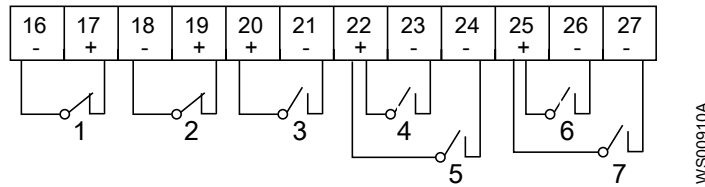

1. Thermal contact for pump 1
2. Thermal contact for pump 2
3. General input
4. Stop level switch
5. Start level switch 1
6. Start level switch 2
7. High-level switch

- Select one of the steps:

Condition	Action
Thermal contact for pump 1	Connect to terminals 16 and 17.
No thermal contact for pump 1	Jumper terminals 16 and 17.

- Select one of the steps:

Condition	Action
Thermal contact for pump 2	Connect to terminals 18 and 19.
No thermal contact for pump 2	Jumper terminals 18 and 19.

- Connect one of the following devices to the general input terminals 20 and 21:
 - Blocking signal
 - Overflow sensor
 - External device that turns on alarms
 - Switch that is used with a personnel alarm
- Connect the level switches.

7.6 Connect an analog level sensor

Select one of the steps:

Type	Terminal connections
Pneumatic level sensor LTU 301 (Accessory for FGC 313/323)	<p>LTU 301:</p> <ol style="list-style-type: none"> 1. Black: Signal ground/Shield 2. White: Signal 3. Red: Power supply (+24 VDC)

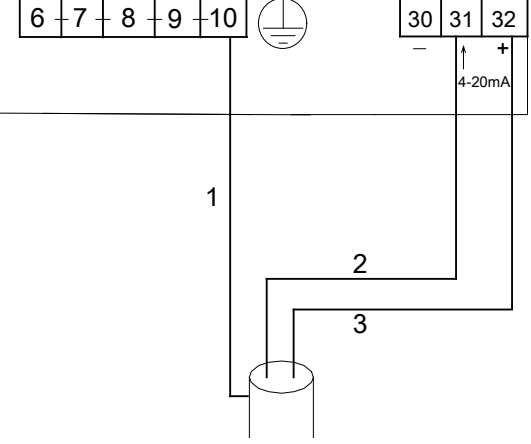
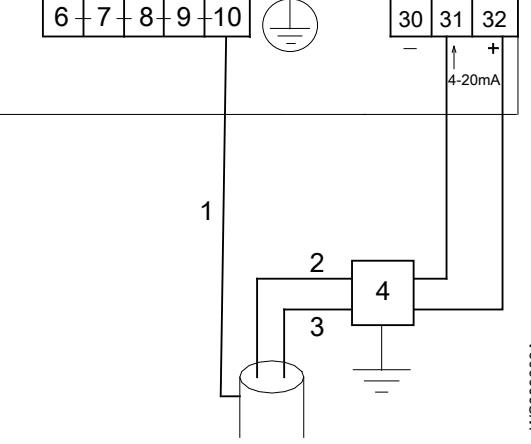
Type	Terminal connections
Analog level sensor LTU 601 (Accessory for FGC 313/323) Or Analog level sensor with the same characteristics and performance as LTU 601	 <p>WS009808A</p> <p>LTU 601: 1. Black: Signal ground/Shield 2. Brown: Signal 3. White: Power supply (+24 VDC)</p>
Analog level sensor LTU 601 (Accessory for FGC 313/323) + Zener barrier Or Analog level sensor with the same characteristics and performance as LTU 601 + Zener barrier	 <p>WS009809A</p> <p>LTU 601: 1. Black: Signal ground/Shield 2. Brown: Signal 3. White: Power supply (+24 VDC) 4. Zener barrier</p>

7.7 Connect a general output signal

Select one of the steps:

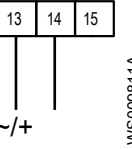
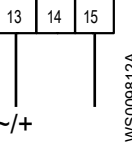
Type	Terminal connections
A signal to turn on an alarm device	 <p>WS009811A</p>
A flush valve or a signal to reset an external device	 <p>WS009812A</p>

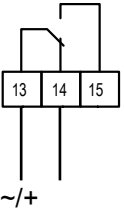
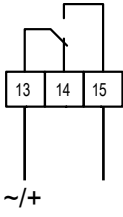
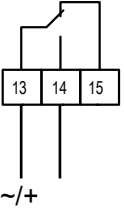
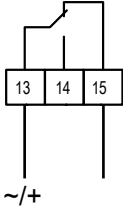
Power to relay	Output to alarm device	Output to flushing valve or reset signal
Off	Active  WS009814A	Passive  WS009815A
On	Passive  WS009813A	Active  WS009816A

7.8 Connect a power supply for external devices

Select one or both of the steps:

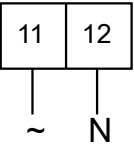
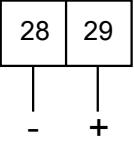
Power supply	Terminal connections
120–240 VAC	 WS009817A
24 VDC	 WS009818A

8 System Setup

8.1 Select a language

A language must be selected the first time a controller is turned on.



W5009799A

1. Press the Left / Up-down button repeatedly until the screen shows the applicable language.
2. Press the Right / Enter button.
The **Value stored** text appears.

8.2 Configure the stop condition of the pump

This configuration is applicable when float switches are used. For more information, see [Float switches](#) on page 10.

1. Go to the **Control mode 15_** menu.
2. Select **Digital**.
3. Press the Right / Enter button.
The **Value stored** text appears.
4. Select one of the steps:

Condition	Action
A stop level switch is used.	Select Stoplevel switch in the Stop condition 15_3 menu.
A stop level switch is not used.	Select Run on time in the Stop condition 15_3 menu.

5. Press the Right / Enter button.
The **Value stored** text appears.
6. Select one of the steps:

Condition	Action
A stop level switch is used.	—
A stop level switch is not used.	Set a time in the Run time 15_4 menu.

7. Press the Right / Enter button.
The **Value stored** text appears.

Continue with [Configure the maximum motor current](#) on page 19.

8.3 Configure pressure or pneumatic level sensors

1. Go to the **Control mode 15_** menu.
2. Select **Analogue**.
3. Press the Right / Enter button.
The **Value stored** text appears.
4. Go to the **Sensor range 15_1** menu.
5. Set the range.
For more information, see the sensor user guide.
6. Press the Right / Enter button.
The **Value stored** text appears.

7. In the pump sump, raise the sensor from the water.
8. Read the value in the **Level 2** menu.
An acceptable value is **0.00** or **0.01**.

Continue with [Configure the start, stop, and high levels](#) on page 19

8.4 Configure an ultrasonic level sensor

1. Go to the **Control mode 15_** menu.
2. Select **Analogue**.
3. Press the Right / Enter button.
The **Value stored** text appears.
4. Go to the **Sensor range 15_1** menu.
5. Set the range.
For more information, see the sensor user guide.
6. Press the Right / Enter button.
The **Value stored** text appears.
7. Calculate the offset that is needed to show the correct level.
If the sensor factory setting is 5 m (16.4 ft), and the pump sump is 3 m (9.84 ft) deep, then the offset is -2 m (6.56 ft).
8. Go to the **Sensor calib. 15_2** menu.
9. Set the offset.
10. Press the Right / Enter button.
The **Value stored** text appears.

Continue with [Configure the start, stop, and high levels](#) on page 19

8.5 Configure the maximum motor current

1. Go to the **High current 10_** menu.
2. Enter the maximum current that is allowed.
This current is usually the same as the nominal current of the pump. In dual pump installations, this value is shared.
If the value is more than 9.0 A, then only one pump is allowed to run at a time. See [Configure the number of pumps to run simultaneously](#) on page 20.
3. Press the Right / Enter button.
The **Value stored** text appears.

8.6 Configure the start, stop, and high levels

1. Go to the **Start level 1 8_** menu.
2. Set the value.
3. Press the Right / Enter button.
The **Value stored** text appears.
4. Go to the **Stop level 1 8_1** menu.
5. Set the value.
6. Press the Right / Enter button.
The **Value stored** text appears.
7. Select one of the steps:

Condition	Action
Single pump installation	Go to the next step.

Condition	Action
Dual pump installation	Configure the Start level 2 8_2 and the Stop level 2 8_3 .

8. Go to the **High level 8_4** menu.
9. Set the value.
10. Press the Right / Enter button.
The **Value stored** text appears.

Continue with [Configure the maximum motor current](#) on page 19.

8.7 Configure the high level switch

This configuration is applicable when an optional high level switch is used. The pump starts when the level in the pump sump exceeds the high level switch.

1. Go to the **Hi. lev. run time 9_6** menu.
2. Set the necessary runtime of the pump after the level drops below the high-level switch.
3. Press the Right / Enter button.
The **Value stored** text appears.

8.8 Configure the pump stop delay

This configuration is applicable for pneumatic level sensors. If the sensor cannot be installed low enough to detect when the pump sump is empty, then this stop delay allows the pump to empty the sump.

1. Go to the **Stop delay range 9_1** menu.
2. Set the depth below the level sensor at which the pump must stop.
The controller calculates the pump run time that is necessary to reach that depth.
3. Press the Right / Enter button.
The **Value stored** text appears.
4. Go to the **Stop delay time 9_** menu.
5. Set the maximum run time.
This time prevents the pump from running dry.
6. Press the Right / Enter button.
The **Value stored** text appears.

8.9 Configure alternation between pumps

1. Go to the **Alternation 9_2** menu.
2. Select one of the steps:

Condition	Action
Always let pump 1 start first.	Select P1 primary .
Always let pump 2 start first.	Select P2 primary .
Change the start order between the pumps after each pump cycle.	Select Start alternation .
Change the start order between the pumps after one pump has run for an hour.	Select Run hour alternation .

3. Press the Right / Enter button.
The **Value stored** text appears.

8.10 Configure the number of pumps to run simultaneously

This configuration is only applicable for dual pump installations.

1. Go to the **Max running pump 9_3** menu.
2. Select **1** or **2**.
3. Press the Right / Enter button.
The **Value stored** text appears.

8.11 Configure a maintenance run schedule

This configuration is used to keep the shape of the mechanical seals in the pumps.

1. Go to the **Auto start int. 9_4** menu.
2. Set the maximum time for the pump to be idle.
3. Press the Left / Up-down button.
The **Value stored** text appears.
4. Go to the **Auto start time 9_5** menu.
5. Set the time for the duration of the maintenance run.
6. Press the Left / Up-down button.
The **Value stored** text appears.

8.12 Configure the maximum runtime for a pump

To avoid a flooded pump sump, the time limit must exceed one pump cycle. The following configurations add time to the pump cycle:

- [Configure the stop condition of the pump](#) on page 18
- [Configure the high level switch](#) on page 20
- [Configure the pump stop delay](#) on page 20

1. Go to the **Max run t. block 9_8** menu.
2. Select one of the steps:

Condition	Action
Block the pump automatically when the maximum runtime is exceeded.	Select Yes .
Let the pump continue to run when the maximum runtime is exceeded.	Select No .

3. Press the Right / Enter button.
The **Value stored** text appears.
4. Select one of the steps:

Condition	Action
The maximum runtime turns on an alarm	Set the time in the Max runtime 9_9 menu.
Disable the maximum runtime alarm	Set 00:00 in the Max runtime 9_9 menu.

5. Press the Right / Enter button.
The **Value stored** text appears.

8.13 Configure a service interval

1. Go to the **Service interval 7_2** menu.
2. Select one of the steps:

Condition	Action
A service alarm turns on after a predetermined number of run time hours.	Set the number of hours.
Disable the service interval function.	Set 0 .

3. Press the Right / Enter button.
The **Value stored** text appears.

8.14 Configure the general input

1. Go to the **Func. gen. input 17_** menu.
2. Select one of the steps:

Condition	Action
An external signal is used to block the pump from restarts when the circuit remains closed.	Select Blocking .
An overflow sensor is used to record the number of times and the duration that the circuit is closed.	Select Overflow sensor .
An external device is used to turn on an alarm when the circuit is closed.	Select External alarm .
A personnel alarm selector switch is used to turn on an alarm after the circuit is closed for a specified time.	Select Personnel alarm .

3. Press the Right / Enter button.
The **Value stored** text appears.
4. Select one of the steps:

Condition	Action
The Personnel alarm is selected.	Enter values in the Work time 17_1 and Warning time 17_2 menus. See Service menus on page 42.
The Personnel alarm is not selected.	—

8.15 Configure the general output

1. Go to the **Gen output func 16_** menu.
2. Select one of the steps:

Condition	Action
A flushing valve is used to clean the pump sump.	Select Flushing valve .
An audible or visual device is used for specified alarms.	Select Common alarm .
A reset is used for an external device that is connected to the general input. See Configure the general input on page 22.	Select Reset .

3. Press the Right / Enter button.
The **Value stored** text appears.
4. Select one of the steps:

Condition	Action
Flushing valve is selected.	<ul style="list-style-type: none"> – Enter the number of pump cycles between each flush in the Flushing interv. 16_3 menu. – Enter the time when the flush valve is open in the Flushing time 16_4 menu.
Common alarm is selected.	<ul style="list-style-type: none"> – In the Common alarm 16_1 menu, select: <ul style="list-style-type: none"> – Continuous for a steady indication – Intermittent for a flashing indication – Specify the alarms that activate the common alarm output in the Com. alarm activ 16_2 menu. See Service menus on page 42.
Reset is selected.	—

8.16 Configure the alarm delays

Alarms can be delayed for a specified time.

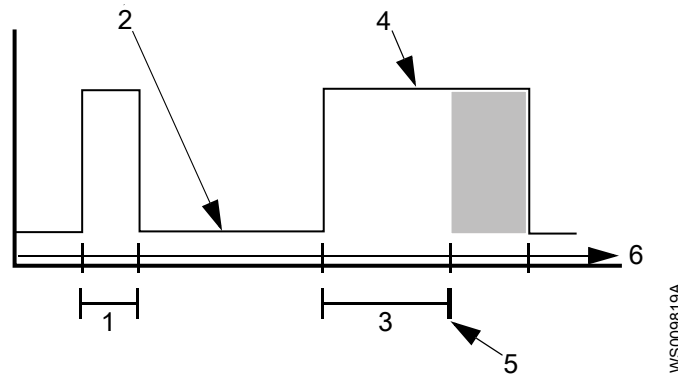

1. Alarm condition that is active a shorter time than the alarm delay
2. No alarm condition
3. Alarm delay
4. Alarm condition
5. Alarm turns on
6. Time

1. Select one or both of the steps:

Type of delay	Action
All alarms, except power failure alarms	Go to the Alarm delay 11_ menu.
Power failure alarms	Go to the Al. delay Powfail 11_1 menu.

2. Set a delay time.
3. Press the Right / Enter button.
The **Value stored** text appears.

8.17 Configure the internal alarm buzzer

1. Go to the **Com. alarm activ 16_2** menu.
2. Select the alarms that turn on the buzzer. For more information, see [Service menus](#) on page 42.
If the general output is configured as **Common alarm**, then the specified alarms also turn on the external device. For more information, see [Configure the general output](#) on page 22.
3. Press the Right / Enter button.
The **Value stored** text appears.

8.18 Restore to the default settings

For the complete list of default settings, see [Setup menus](#) on page 37 and [Service menus](#) on page 42.

1. Go to the **Set default val. 20_5** menu.
2. Select one of the steps:

Condition	Action
An analog level sensor is installed in a Compit pump sump.	Select the Compit analogue value set.
The start and stop level switches regulate the level.	Select the Level regulator value set.
The controller is installed in the Netherlands.	Select the NL analogue value set.

3. Press the Right / Enter button.
The controller makes a quick restart and the **Value stored** text appears.

9 Operation

9.1 Push-button functions

Buttons

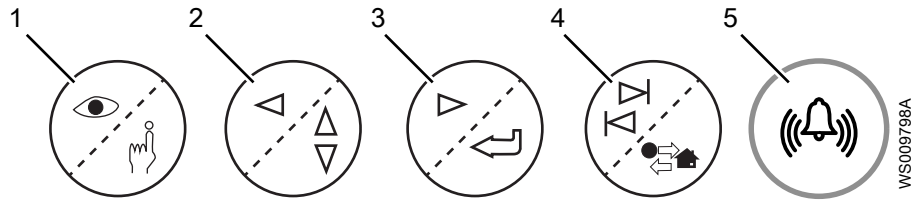

1. View / Write
2. Left / Up-down
3. Right / Enter
4. Shift / Home
5. Reset

WS009798A

Menu navigation

Action	Press and hold	Press
Move forward to the next menu.	—	
Move backward to the previous menu.	—	
Move forward to the next menu group.		
Move backward to the previous menu group.		
Switch between any menu and the Alarm log 1 menu.	—	

Menu setup

Action	Press and hold	Press
Switch from read to write mode. <ul style="list-style-type: none"> • If the value can be changed, then a cursor flashes. • If the value cannot be changed, then a Read-only message appears. 	—	

Action	Press and hold	Press
Increase a value.	—	
Decrease a value.		
Move to the next digit or text value.	—	
Move to the previous digit or text value.		
Save the value after the last digit is set. <ul style="list-style-type: none"> • Value stored appears when the value is saved. • Low value appears when the value is too low. • High value appears when the value is too high. • Store failed appears when the internal communication circuits are busy. 	—	
Switch from write to read mode without saving the value.	—	

9.2 View the run time data

Select the steps to view the data:

Type of data	Action
The present level in the pump sump	Go to the Level 2 menu.
The length of time that pump 1 ran	Go to the P1 run hour 3_ menu.
The length of time that pump 2 ran	Go to the P2 run hour 3_2 menu.
The number of times that pump 1 started	Go to the P1 start counter 3_1 menu.
The number of times that pump 2 started	Go to the P2 start counter 3_3 menu.
The present current of pump 1	Go to the P1 current 4_ menu.
The present current of pump 2	Go to the P2 current 4_1 menu.
The accumulated overflow time	Go to the Overflow time 5_ menu.
The number of times that overflow occurred	Go to the Overflow count 5_1 menu.

9.3 Reset the run time data

- Go to the applicable menu:
 - **P1 run hour 3_**
 - **P2 run hour 3_2**
 - **P1 start counter 3_1**
 - **P2 start counter 3_3**

- **Overflow time 5_**
 - **Overflow count 5_1**
2. Press the View / Write button.
The **Reset value?** text appears.
 3. Press the Left / Up-down button to select **Yes**.
 4. Press the Right / Enter button.
The **Value stored** text appears.

9.4 Control a pump manually

Select one of the steps:

Condition	Action
Start a pump.	Press the Hand-Off-Auto switch to the H position.
Stop a pump.	Press the Hand-Off-Auto switch to the middle position.
Block a pump.	<ol style="list-style-type: none"> 1. Select Blocked in the menus: <ul style="list-style-type: none"> – P1 State 7_ for pump 1 – P2 State 7_1 for pump 2 2. Press the Right / Enter button.

9.5 Control a pump automatically

1. Press the Hand-Off-Auto switch to the **A** position.
2. Select **Auto** in the menus:
 - **P1 State 7_** for pump 1
 - **P2 State 7_1** for pump 2

Based on the configured settings, the controller starts the pump.

9.6 Acknowledge an alarm

Alarms can turn on an audible or visual device according to the setting in the **Com. alarm activ 16_2** menu.

- Press the Reset button.
The device turns off.

9.7 Prevent a personnel alarm

This function is only applicable if the **Funct. gen. input 17_** menu is set to **Personnel alarm**, see [Service menus](#) on page 42.

An external selector switch starts the personnel alarm function.

- Extend the work time and prevent the alarm from setting off with one of the steps:
- Activate the selector switch twice.
 - Press the Reset button.

9.8 View the alarm log

The alarm log shows the ten latest active and inactive alarms.

1. Go to the **Alarm log 1** menu.
2. Press the View / Write button.
3. Press the Left / Up-down button to browse the log.
4. Press the View / Write button to exit the mode.

9.9 Clear the alarm log from inactive alarms

1. Go to the **Alarm log 1** menu.
2. Press the View / Write button.
3. Press the Right / Enter button.

The **Log cleared** text appears.

The **Alarm log 1** menu shows the number of active alarms.

9.10 View or reset the hours since the last service

1. Select one of the steps:
 - Go to the **P1 after service 7_3** menu for pump 1.
 - Go to the **P2 after service 7_4** menu for pump 2The screen shows the number of hours since the last service.
2. Press the View / Write button.

The **Reset value?** text appears.
3. Press the Left / Up-down button to select **Yes**.
4. Press the Right / Enter button.

The **Value stored** text appears.







10 Maintenance

10.1 Preventive maintenance

Make sure that the unit is free from dust. Use a dry, soft cloth.

11 Troubleshooting

11.1 Common problems

Symptom	Remedy
  <ul style="list-style-type: none"> The power-on LED does not light up. The Pwr ON LED on the main board does not light up. 	<ul style="list-style-type: none"> If the main power supply is turned off, then check the external main switch and main fuse. If the error is not found, then contact the local sales and service representative.
 <ul style="list-style-type: none"> The pump status LED flashes. The Phase fail LED on the main board lights up. 	<ul style="list-style-type: none"> If the pump start is delayed, then press the reset button. Check that no phase is missing. If the problem is corrected, then press the reset button. If the error is not found, then contact the local sales and service representative.
 <ul style="list-style-type: none"> The pump status LED lights up. The Blocked LED on the main board lights up. 	<ul style="list-style-type: none"> Check that the Hand-Off-Auto switch is set to A. Check that Auto is selected in the P1 State 7_ or P2 State 7_1 menu. If the lights up when the pump starts, then contact the local sales a service representative.
  <ul style="list-style-type: none"> The pump failure LED lights up. The Failure LED on the main board lights up. 	<ul style="list-style-type: none"> Check that the Alarm log 1 list contains the alarm P1 high temp or P2 high temp. If not, then contact the local sales and service representative. Check that the thermal contact is connected to the terminals. If thermal contacts are not used, then make sure that the terminals are jumpered. Check if the pump is damaged, for example, a bearing or winding failure. Check if the pump impeller is clogged. If the problem is corrected, then acknowledge the alarm. For more information, see Acknowledge an alarm on page 26.
<p>The Alarm log 1 list contains the alarm P1 tripped or P2 tripped.</p>	<ul style="list-style-type: none"> If the pump has not tripped, then contact the local sales and service representative. Check that the High current 10_ menu is set to the correct maximum current. Check if the pump runs on only two phases. Check if the pump is damaged, for example a bearing or winding failure. Check if the pump impeller is clogged. If the problem is corrected, then acknowledge the alarm. For more information, see Acknowledge an alarm on page 26.

11.2 View status of the input and output signals

The pump controller groups the input and output signals in four groups:

- A
- B

- C
- D

For more information, see [Signal Positions](#) on page 30.

Go to the **Status port A, B 20_** or **Status port C, D 20_1** menu.

- 0 shows that the input is not active for this position.
- 1 shows that the input is active for this position.

11.3 Invert the input signals

The digital signals can be inverted to change the mode of operation from closing to opening, or in the opposite way.

See [Signal Positions](#) on page 30.

1. Go to the **Invert port A, B 20_2** or **Invert port C, D 20_3** menu.
 - 0 shows that there is no inversion for this position.
 - 1 shows that the input is inverted for this position.
2. If applicable, then invert an input signal.

11.4 Signal Positions

A port menu shows information for 16 signals. The format is a long string of 0's and 1's, for example: 0111100000100000.

The leftmost digit is position 1, while the rightmost digit is position 16.

Position	Port A and B	Signal type	Signal inversion
1	P2 Run	Digital out	—
2	P2 Present	Digital in	—
3	LED High level	Digital out	—
4	LED P1 failure	Digital out	—
5	LED P1 blocked	Digital out	—
6	P1 Run	Digital out	—
7	Common alarm	Digital out	—
8	Buzzer	Digital out	—
9	Not used	—	—
10	Not used	—	—
11	P1 Thermo	Digital in	Yes
12	Auto position H-0-A P1	Digital in	Yes
13	Not used	—	—
14	Hand position H-0-A P1	Digital in	Yes
15	Not used	—	—
16	Not used	—	—

Position	Port C and D	Signal type	Signal inversion
1	Not used	—	—
2	P2 Thermo	Digital in	Yes
3	LED P2 blocked	Digital out	—
4	LED P2 fail	Digital out	—
5	Not used	—	—
6	Auto position H-0-A P2	Digital in	Yes
7	Hand position H-0-A P2	Digital in	Yes

Position	Port C and D	Signal type	Signal inversion
8	Start switch 2	Digital in	Yes
9	Power fail	Digital in	Yes
10	Reset button	Digital in	Yes
11	High-level switch	Digital in	Yes
12	Not used	—	—
13	Not used	—	—
14	Start switch 1	Digital in	Yes
15	Stop switch	Digital in	Yes
16	External alarm	Digital in	Yes

11.5 Run the diagnostic programs

All other functions are disabled when a diagnostic program runs.

After 10 minutes of idle time, the pump controller automatically reverts to normal operation.

1. Go to the **Diagnos. program 20_4** menu.
2. Select one of the diagnostic programs.

Program	Description	Results
01	Text version	X.XX
02	LON and relay card version	X.XX
10	Digital input	001001100100
11	LED output	Flashes
	Buzzer	Sounds
	Common alarm and external alarm device	Flashes
20	Analog input	Shows level in bits: 0–1023
21	Applicable only to units with a LON module	Shows acknowledged rate of communication in %
22	Applicable only to units with a LON module	Shows the approved proportion of test messages in %
23	Applicable only to units with a LON module	Shows how long a test message takes to reach its destination (milliseconds)
30	P1 current input	Shows current in bits for L2 and L3: 0–255 0 A = 7 or 8
31	P1 current input	Shows current in bits for L2 and L3: 0–255 0 A = 7 or 8
Off	Stop a diagnostic program	—

12 Technical Reference

12.1 Dimensions

Small type enclosure

This type is applicable when no main breaker or fuses are needed in the pump monitor panel.

Parameter	Value
Dimensions, W x D x H	255 x 180 x 100 mm (10.0 x 7.09 x 3.94 in)
Weight	<ul style="list-style-type: none"> • 1.2 kg for 1-pump controller • 1.4 kg for 2-pump controller
Mounting	Wall
Cable entries	Knock-out holes: <ul style="list-style-type: none"> • 3 pieces M25 • 5 pieces M20

Large type enclosure

This type is applicable when a main breaker, fuses, or communication is included in the pump monitor panel.

Parameter	Value
Dimensions, W x D x H	300 x 400 x 180 mm (11.8 x 15.7 x 7.09 in)
Weight	<ul style="list-style-type: none"> • 5.4 kg for 1-pump controller • 5.8 kg for 2-pump controller
Mounting	Wall
Cable entries	Knock-out holes: <ul style="list-style-type: none"> • 2 pieces M40 • 3 pieces M32 • 3 pieces M25 • 4 pieces M20

12.2 Environmental requirements

Parameter	Value
Operating temperature	-20°C to +45°C (-4°F to 113°F)
Storage temperature	-20°C to +70°C (-4°F to 158°F)
Operating humidity	Relative humidity, non-condensing, 90%
Altitude	Maximum 2000 m (6500 ft)

12.3 IP rating

IP 54

12.4 Electrical data

Parameter	Value
Supply voltage	<ul style="list-style-type: none"> • 1-phase, 120 VAC – 240 VAC • 3-phase with neutral, 200 VAC – 460 VAC • 3-phase without neutral, 230 VAC
Frequency	50 Hz or 60 Hz

Parameter	Value
3-phase, rated current for the pump	<ul style="list-style-type: none"> • 11 A for one pump • 18 A for two pumps
Current output for 120 VAC – 240 VAC	Maximum 4 A. The output can be used only when neutral is connected.
Power output for 24 VDC	Maximum 10 W
Internal current consumption	<50 mA at 400 V
General relay output	5 A, 250 VAC
Analog level sensor input	4–20 mA The supply from the pump controller can carry a maximum of 18 VDC.
Main supply fuse	Maximum 25 A
Internal fuse	1 A, non-replaceable

12.5 Terminals and connectors

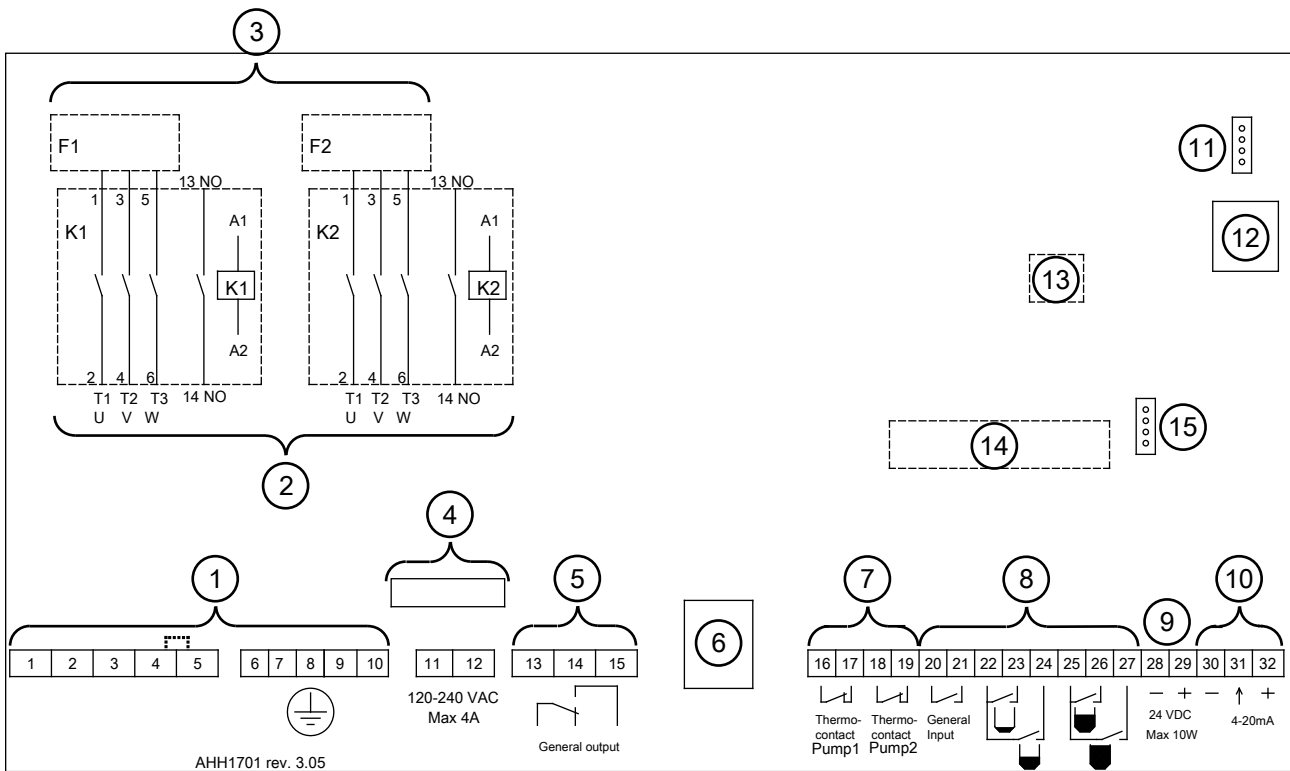

Location	Function	Terminal	Description
1	Power supply	1–5	3-phase and neutral 200 VAC – 460 VAC, 1-phase 120 VAC – 240 VAC, or 3-phase 230 VAC
		6–10	Earth terminal: 5 pieces 6 mm
2	Contactors	—	Connection for pump 1, maximum 12 A
		—	Connection for pump 2, maximum 12 A
3	Current transformers	—	Current transformer, pump 1
		—	Current transformer, pump 2
4	Power supply for	11–12	120 VAC – 240 VAC, 4 A

Location	Function	Terminal	Description
	external device	—	Fuse F3: T4AH
5	General output	13–15	Potential free contact Maximum 250 VAC, 5 A
6	Connector	—	For Hand-Off-Auto switches and reset button
7	Thermal contact input	16–17	For pump 1 If not used, then these terminals must be jumpered.
		18–19	For pump 2 If not used, then these terminals must be jumpered.
8	Digital input	20–21	General input
		22, 23	Stop level switch input Terminal 22 is a common terminal for stop level switch and start level switch 1.
		22, 24	Start level switch 1 input Terminal 22 is a common terminal for stop level switch and start level switch 1.
		25, 26	Start level switch 2 input Terminal 25 is a common terminal for start level switch 2 and high level switch.
		25, 27	High level switch input Terminal 25 is a common terminal for start level switch 2 and high level switch.
9	Power supply for external device	28–29	24 VDC
10	Analog input	30–32	Level sensor, 4–20 mA
11	Expansion module	—	Connector for an optional battery backup module 11.1 V, 1500 mAh
12	Connector	—	Screen unit
13	Connector	—	Text memory
14	Connector	—	Processor
15	Connector	—	Optional equipment, for example, LON module, hour counter, relay card, or communication module

12.6 Menu chart

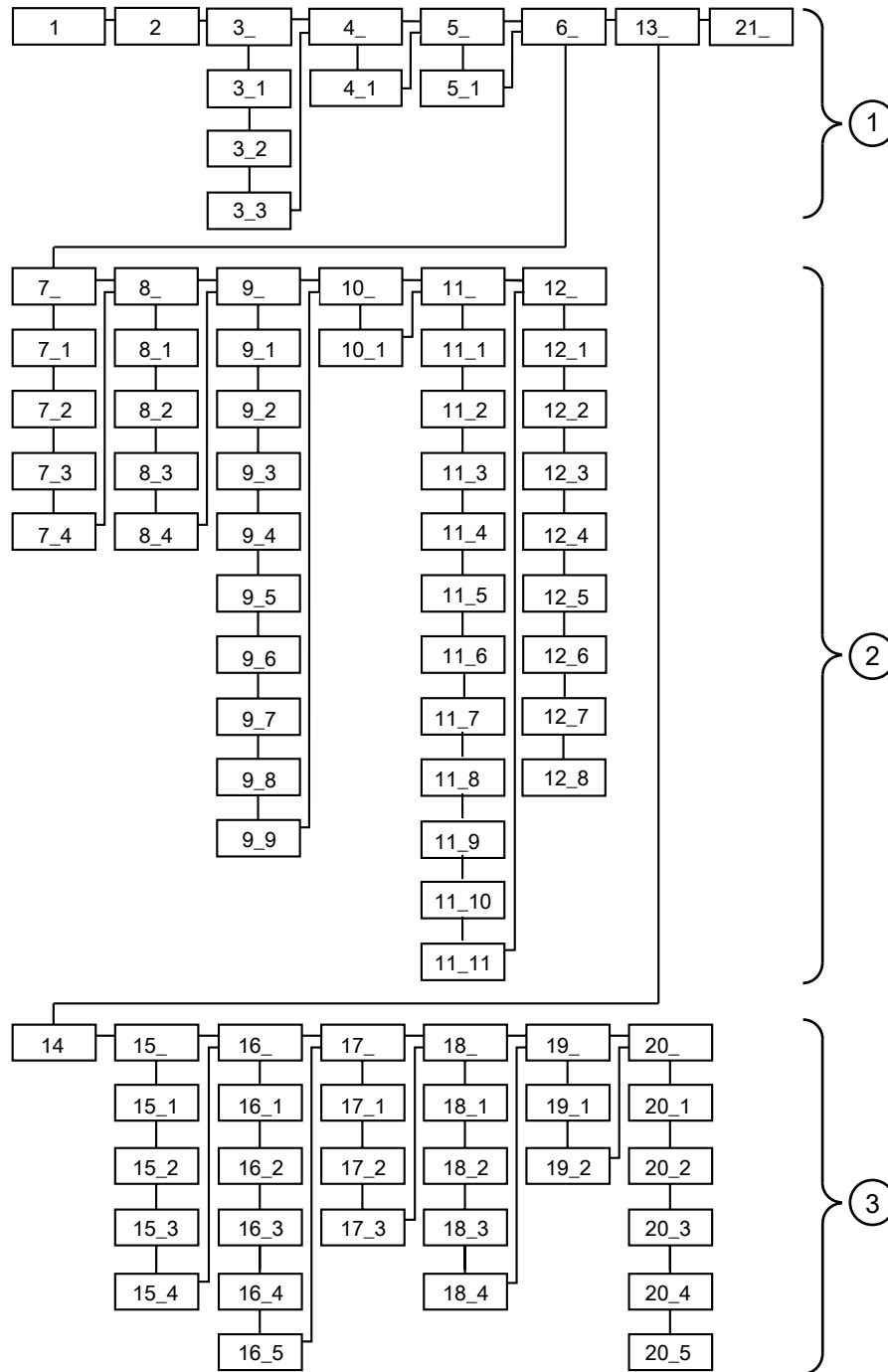

1. For more information, see [Operation menus](#) on page 36.
2. For more information, see [Setup menus](#) on page 37.
3. For more information, see [Service menus](#) on page 42.

WS009788A

12.7 Operation menus

Menu number	Menu name	Description
1	Alarm log	The number of recorded alarms, and a list of recorded alarms that can contain the following data: <ul style="list-style-type: none"> • Mains error • High level • Hi.lev.float • P1 high temp • P1 tripped • P1 max. run • P2 high temp • P2 tripped • P2 max run • External • Sensor Fault • P1 no resp. • P2 no resp. • Inval. setp. • Pers. alarm • Overflow • Test call! • Service P1 • Service P2
2	Level	The level in the pump sump. This menu appears only when Control mode menu 15_ is set to Analogue .
3_	P1 run hour	The total running time for pump 1
3_1	P1 start counter	The total start count for pump 1
3_2	P2 run hour	The total running time for pump 2 This menu only appears in dual-pump installations.
3_3	P2 start counter	The total start count for pump 2. This menu only appears in dual-pump installations.
4_	P1 current	The current reading for pump 1. The range is 0.0 A – 99.9 A
4_1	P2 current	The current reading for pump 1 The range is 0.0 A – 99.9 A This menu only appears in dual-pump installations.
5_	Overflow time	The total overflow time This menu only appears when the Func. gen. input 17_ menu is set to Overflow input .
5_1	Overflow count	The total number of overflows This menu only appears when the Func. gen. input 17_ menu is set to Overflow input .
6	Parameter	<ul style="list-style-type: none"> • No hides the setup menus. • Yes shows the setup menus.
13	Service	<ul style="list-style-type: none"> • No hides the service menus. • Yes shows the service menus.

Menu number	Menu name	Description
21_	Language	<p>The language that is used on the screen.</p> <ul style="list-style-type: none"> • English • Deutsch • Nederlands • Français • Dansk • Svenska • Norsk • Español • Magyar • Suomi • Italiano • Russian • Polski <p>For controller versions without a screen, the setpoint is transmitted from a handheld unit.</p> <p>When a set of default values are restored, the Language setting is not affected.</p>

12.8 Setup menus

The setup menus appear when the **Parameter 6_** menu is set to **Yes**.

For controller versions without a screen, the settings are transmitted from a handheld unit.

Menu number	Menu name	Description	Default settings		
			Compit analogue	Level regulator	NL analogue
7_	P1 State	Program controlled automatic or blocked state for pump 1 <ul style="list-style-type: none"> • Auto • Blocked 	Auto	Auto	Auto
7_1	P2 State	Program controlled automatic or blocked state for pump 2 <ul style="list-style-type: none"> • Auto • Blocked This menu appears in dual-pump installations.	Auto	Auto	Auto
7_2	Service interval	The service interval time in hours When the pump has run this time, a service alarm is sent. 0 disables the function.	—	—	—
7_3	P1 after service	The number of running hours since the last service on pump 1 Reset this value after service!	—	—	—
7_4	P2 after service	The number of running hours since the last service on pump 2 Reset this value after service! This menu appears in dual-pump installations.	—	—	—
8_	Start level 1	The start level for pump 1 The range is -99.99 m to 99.99 m. If alternation is used, then it is the start level for the pump that starts first. Alternation is specified in the Alternation 9_2 menu. This menu appears when the Control mode 15_ menu is set to Analogue .	0.15	0.60	0.35

Menu number	Menu name	Description	Default settings		
			Compit analogue	Level regulator	NL analogue
8_1	Stop level 1	The stop level for pump 1 The range is –99.99 m to 99.99 m. If alternation is used, then it is the start level for the pump that starts first. Alternation is specified in the Alternation 9_2 menu. This menu appears when the Control mode 15_ menu is set to Analogue .	0.10	0.20	0.28
8_2	Start level 2	The start level for pump 2 The range is –99.99 m to 99.99 m. If alternation is used, then it is the start level for the pump that starts first. Alternation is specified in the Alternation 9_2 menu. This menu appears when the Control mode 15_ menu is set to Analogue . This menu appears in dual-pump installations.	0.20	0.70	0.40
8_3	Stop level 2	The stop level for pump 2 The range is –99.99 m to 99.99 m. If alternation is used, then it is the start level for the pump that starts first. Alternation is specified in the Alternation 9_2 menu. This menu appears when the Control mode 15_ menu is set to Analogue . This menu appears in dual-pump installations.	0.10	0.30	0.28
8_4	High level	High level alarm limit The range is –99.99 m to 99.99 m. This menu appears when the Control mode 15_ menu is set to Analogue .	0.25	0.90	0.50
9_	Stop delay time	Delays the stop of the pump with the set time This setting is only relevant for stop level 1. The range is 00:00 to 10:00 in the format min:s. If a delay has been entered in the Stop delay range 9_1 menu, then the value in the Stop delay time 9_ menu is the maximum allowed stop delay time.	02:00	00:00	00:10
9_1	Stop delay range	The pump can continue to run until the level in the pump sump drops below the stop level. The pump controller calculates the stop delay time required to reach this lower level. The range is 0.0 m to 2.50 m. The calculated stop delay time is limited by the value entered in the Stop delay time (9_1) menu. 0 disables the function. This menu appears when the Control mode 15_ menu is set to Analogue .	00.26	00.00	00.10
9_2	Alternation	The method of the pump operation <ul style="list-style-type: none"> • P1 primary: Pump 1 always starts first. • P2 primary: Pump 2 always starts first. • Start alt.: The pumps alternate. • Run hour alt.: The pumps alternate after one hour of operation. This menu appears in dual-pump installations.	Start alt.	P1 primary	Start alt.

Menu number	Menu name	Description	Default settings		
			Compit analogue	Level regulator	NL analogue
9_3	Max running pump	The maximum number of pumps that are allowed to run at the same time <ul style="list-style-type: none"> • 1 • 2 This setting is only relevant for dual-pump installations.	2	2	1
9_4	Auto start int.	If a pump does not start in the set interval, then this function starts the pump for a maintenance run. The range is 1 h – 200 h. The running time is set in the Auto start time 9_5 menu.	96	96	96
9_5	Auto start time	The running time when started by the auto start function The range is 00:00 to 59:99 min:s. 0 disables the function. The auto start interval is set in the Auto start int. 9_4 menu.	00:05	00:00	00:01
9_6	Hi.lev. run time	The backup control that activates when there is a level sensor failure The high-level switch starts the available pumps. They will then run for the period that is set in this menu. The range is 00:00 to 10:00 in the format min:s.	00:20	02:00	00:00
9_7	High temp. block	Determines if the high temperature alarm blocks the pump <ul style="list-style-type: none"> • No • Yes 	Yes	Yes	Yes
9_8	Max run t. block	Determines if the maximum run time alarm will block the pump <ul style="list-style-type: none"> • No • Yes 	Yes	Yes	No
9_9	Max run time	The maximum time that a pump is allowed to run continuously The range is 00:00 to 50:00 in the format min:s. 0 disables the function.	30:00	00:00	00:00
10_	High current	The maximum allowed pump motor current The value is normally the nominal current of the pump. The pump controller adds a 5% margin. The range is 0.8 A to 12.0 A. If the maximum current is set to more than 9.0 A per pump in a dual-pump installation, then only one pump can run at a time. This setting overrides the settings in the Max running pump 9_3 menu.	5.3	4.7	1.0
10_1	Automatic reset	Automatic reset of the pump after an overcurrent failure <ul style="list-style-type: none"> • No: Blocks the pump • Yes: Attempts to start the pump a second time 	No	Yes	Yes
11_	Alarm delay	The time before an alarm is registered This setting is used for all alarms except the power failure alarms. The range is 00:00 to 59:59 in the format min:s.	00:05	00:05	00:05
11_1	Al. delay Powfail	The time before a power failure alarm is registered The range 0 min to 960 min.	00:05	01:00	00:05
11_2	Resp. err. alarm	<ul style="list-style-type: none"> • No: No alarm when pump response is missing • Yes: Alarm when pump response is missing 	Yes	Yes	Yes

Menu number	Menu name	Description	Default settings		
			Compit analogue	Level regulator	NL analogue
11_3	Transmit alarm	<p>The alarm transmission method</p> <ul style="list-style-type: none"> • Local: Alarms are not transmitted. • Remote: Alarms are transmitted to a central system or an SMS receiver. • Clear: The alarm buffer is cleared and the transmission changes to Remote. <p>This menu does not appear when the Communication 18_ menu is set to None.</p>	Local	Local	Local
11_4	Alarm prio.index	<p>Alarm for which the alarm priority can be set in the Alarm priority 11_5 menu.</p> <ul style="list-style-type: none"> • Mains error • High level • Hi.lev.float • P1 high temp • P1 tripped • P1 max. run • P2 high temp • P2 tripped • P2 max run • External • Sensor Fault • P1 no resp. • P2 no resp. • Inval. setp. • Pers. alarm • Overflow • Test call! • Service P1 • Service P2 <p>This menu does not appear when the Communication 18_ menu is set to None.</p>	—	—	—
11_5	Alarm priority	<p>The alarm priority for the alarm selected in the Alarm prio.index 11_4 menu</p> <ul style="list-style-type: none"> • A • B • C • D <p>The alarm priority determines how the alarm is handled.</p> <p>This menu does not appear when the Communication 18_ menu is set to None.</p>	—	—	—
11_6	Code gen. input	<p>Alternative alarm code to use for the general input</p> <p>The range is 1 to 9999.</p> <p>This menu does not appear when the Communication 18_ menu is set to None.</p>	7	7	—
11_7	D-Alr.start time	<p>The start time for dialing out the alarms with priority D</p> <p>The range is 00:00 to 23:59 in the format h:min.</p> <p>This menu does not appear when the Communication 18_ menu is set to None.</p>	00:00	00:00	—

Menu number	Menu name	Description	Default settings		
			Compit analogue	Level regulator	NL analogue
11_8	D-Alarm end time	The stop time for dialing out the alarms with priority D The range is 00:00 to 23:59 in the format h:min. This menu does not appear when the Communication 18_ menu is set to None .	00:00	00:00	—
11_9	Test alarm int. days	The frequency by which the test alarm is sent The range is 0 days to 99 days. This menu does not appear when the Communication 18_ menu is set to None .	0	0	—
11_10	Test alarm time	The time of day when the test alarm is sent The range is 00:00 to 23:59 in the format h:min. This menu does not appear when the Communication 18_ menu is set to None .	00:00	00:00	—
11_11	Test alarm state	The current state of the test alarm This setting can also be used to activate the test alarm manually. • Off • On This menu does not appear when the Communication 18_ menu is set to None .	Off	Off	—
12_	Date and time	Date and time in the RTU This menu does not appear when the Communication 18_ menu is set to None .	—	—	—
12_1	Tele no. CS/SMS	Telephone number to the central system or an SMS receiver T=Tone dial This menu does not appear when the Communication 18_ menu is set to None .	—	—	—
12_2	Tele no. SMS 2	Telephone number 2 to an SMS receiver This number is only relevant if Aquacom/SMS is selected in the Protocol COM1 18_2 menu. This menu does not appear when the Communication 18_ menu is set to None .	—	—	—
12_3	Tele no. SMS 3	Telephone number 3 to an SMS receiver This number is only relevant if Aquacom/SMS is selected in the Protocol COM1 18_2 menu. This menu does not appear when the Communication 18_ menu is set to None .	—	—	—
12_4	SMS Ack. time	The time that the pump controller waits for an acknowledgment call or SMS reply After this time, the SMS alarm is sent to the next telephone number in the list. The range is 0 min to 60 min. 0 disables the function and the SMS is sent directly to all valid telephone numbers. This setting is only relevant if Aquacom/SMS is selected in the Protocol COM1 18_2 menu. This menu does not appear when the Communication 18_ menu is set to None .	5	5	—

Menu number	Menu name	Description	Default settings		
			Compit analogue	Level regulator	NL analogue
12_5	SMS P-alarm	States if an SMS is sent when an alarm is deactivated <ul style="list-style-type: none"> • No • Yes This setting is only relevant if Aquacom/SMS is selected in the Protocol COM1 18_2 menu. This menu does not appear when the Communication 18_ menu is set to None .	Yes	Yes	—
12_6	Station name	The station name is included in any SMS to GSM telephones This menu does not appear when the Communication 18_ menu is set to None .	FGC	FGC	—
12_7	Station no./id	The unique number of the station in the system The range is 0 to 899. This menu does not appear when the Communication 18_ menu is set to None .	999	999	—
12_8	Trend resolution	The frequency at which trend data is stored and transmitted to the central system The range is 0 min to 60 min. In Aquacom, 1 minute or 5 minute periods are used. 0 disables trend sampling. This menu does not appear when the Communication 18_ menu is set to None .	5	5	—

12.9 Service menus

The setup menus appear when the **Service 13_** menu is set to **Yes**.

For controllers without a screen, the settings are transmitted from a handheld unit.

Menu number	Menu name	Description	Default settings		
			Compit analogue	Level regulator	NL analogue
14	System version	The system version	—	—	—
15_	Control mode	<ul style="list-style-type: none"> • Digital: Digital level switches are used for starting and stopping the pumps. • Analogue: An analog sensor is used for starting and stopping the pumps. 	Analogue	Digital	Analogue
15_1	Sensor range	The level sensor range The range is 0.0 m to 20.0 m. This appears when the Control mode 15_ menu is set to Analogue .	2.50	2.50	2.50
15_2	Sensor calib.	Offset for sensor calibration The range is -20.0 m to 20.0 m. This menu appears when the Control mode 15_ menu is set to Analogue .	00:00	00:00	00:25
15_3	Stop condition	<ul style="list-style-type: none"> • Stop level switch: The level switch stops the pump. • Run on time: Pump is stopped after a time. This menu appears when the Control mode 15_ menu is set to Digital .	Run on time	Stop level switch	—

Menu number	Menu name	Description	Default settings		
			Compit analogue	Level regulator	NL analogue
15_4	Run time	The pump run time when the Stop condition 15_3 menu is configured to Run on time No stop level switch is used. The range is 00:00 to 10:00 in the format min:s. This menu appears when the Control mode 15_ menu is set to Digital .	00:20	00:30	—
16_	Gen.output func	The setting is used for the general output. <ul style="list-style-type: none"> • Common alarm • Reset • Flushing valve 	Comm on alarm	Comm on alarm	—
16_1	Common alarm	<ul style="list-style-type: none"> • Continuous: Common alarm output is on continuously. • Intermittent: Common alarm is intermittent by one second. 	Intermittent	Intermittent	Continuous
16_2	Com. alarm activ	Alarms that activate the common alarm output <ul style="list-style-type: none"> • 0 = Off • 1 = On Position: 1. Overflow 2. Pers. Alarm 3. Inval. setp. 4. P2 no resp. 5. P1 no resp. 6. Sensor Fault 7. External 8. P2 max. run 9. P2 tripped 10 P2 high temp 11 P1 max. run 12 P1 tripped 13 P1 high temp 14 Hi.lev.float 15 High level 16 Mains error	0110 0111 1111 1111	1100 0001 1111 1111	1100 0001 1111 1111
16_3	Flushing interv.	The number of pump cycles between each flush The range is 1 h to 200 h. This setting is relevant if the Gen.output func 16_ menu is set to Flushing valve	0	0	—
16_4	Flushing time	The time the flushing valve is open The range is 00:00 to 59:59 in the format min:s. 0 disables the function. This setting is relevant if the Gen.output func 16_ menu is set to Flushing valve .	0	0	—
16_5	Buzzer	The buzzer operation <ul style="list-style-type: none"> • Off • On 60 s • On 	On 60 s	On	Off

Menu number	Menu name	Description	Default settings		
			Compit analogue	Level regulator	NL analogue
17_	Func. gen. input	The function for the general input <ul style="list-style-type: none"> • External alarm • Personnel alarm • Blocking • Overflow 	External alarm	External alarm	External alarm
17_1	Work time	When the work time has elapsed, a warning time begins to run. The range is 0 min to 240 min. The menu appears when the Func. gen. input 17_ menu is set to Personnel alarm .	240	45	—
17_2	Warning time	A warning time during which an acknowledgment from the personnel is required. If no acknowledgment is received within this time, the personnel alarm is sent to the central system or the SMS receivers. The range is 1 min to 15 min. The menu appears when the Func. gen. input 17_ menu is set to Personnel alarm .	15	15	—
17_3	Ex mode	Function for EX-classified environment If no water can be detected in the pump sump, then the pumps will be prevented from starting. <ul style="list-style-type: none"> • Off • On 	On	Off	Off
18_	Communicat. COM1	Type of equipment used to communicate with the SCADA system or the SMS receivers <ul style="list-style-type: none"> • None • Hayes modem • GSM/Hayes predef • RS232 HDX • RS232 FDX 	None	None	None
18_1	Speed COM1	Communication speed used with the SCADA system or the SMS receivers <ul style="list-style-type: none"> • 2400 bps • 4800 bps • 9600 bps • 19200 bps • 57600 bps 	9600 bps	9600 bps	—
18_2	Protocol COM1	Communication protocol used with the SCADA system or the SMS receivers <ul style="list-style-type: none"> • AquaCom fixed • AquaCom dialled • AquaCom/SMS • Modbus fixed • Modbus dialled • Comli fixed • Comli dialled 	AquaCom dialled	AquaCom dialled	—
18_3	RTS delay COM1	Request to send (RTS) signal delay in the communication with the central system. This setting is only relevant when the Communicat. COM1 18_ menu is set to RS232 HDX . The range is 25 ms to 1000 ms.	200	200	—

Menu number	Menu name	Description	Default settings		
			Compit analogue	Level regulator	NL analogue
18_4	Max buffer size	Limits the amount of data sent during trend data transfers to the central system. The range is 80 to 4000.	500	500	—
19_	LON node	The node address for LON communication. The range is 1 to 32. In a LON system, this address must be unique for each pump controller within a group. A group consists of pump controllers connected on the same physical media.	1	1	—
19_1	LON group	The group address for LON communication. The range is 1 to 9. The pump controller communicates with a LON-Gateway. This gateway address is the group address.	1	1	—
19_2	LON domain	Domain address for LON communication. The range is 0 to 9. If a LON repeater is used, then enter the domain value 1 to 9. Otherwise, use 0.	0	0	0
20_	Status port A, B	The status of digital inputs and outputs for ports A and B <ul style="list-style-type: none"> • 0 = Not active • 1= Active Position: <ol style="list-style-type: none"> 1. P2Run 2. P2Pres 3. LEDHiLev 4. LEDP1Err 5. LEDP1Bik 6. P1Run 7. ComAlr 8. Buzz 9. - 10.- 11P1Thermo 12P1Auto 13- 14P1Hand 15- 16- 	Read only	Read only	Read only

Menu number	Menu name	Description	Default settings		
			Compt analogue	Level regulator	NL analogue
20_1	Status port C, D	<p>The status of digital inputs and outputs for port C and D</p> <ul style="list-style-type: none"> • 0 = Not active • 1= Active <p>Position:</p> <ol style="list-style-type: none"> 1. - 2. P2Thermo 3. LEDP2Blk 4. LEDP2Err 5. - 6. P2Auto 7. P2Hand 8. StartSens2 9. PowFail 10.Reset 11DigHiLev 12- 13- 14StartSens 15StopSens 16ExtAlr 	Read only	Read only	Read only
20_2	Invert port A, B	<p>Inversion of digital inputs and outputs for port A and B</p> <ul style="list-style-type: none"> • 0 = No inversion • 1= Inversion <p>In write mode, the names of the digital inputs are shown .</p> <p>Position:</p> <ol style="list-style-type: none"> 1. P2Run 2. P2Pres 3. LEDHiLev 4. LEDP1Err 5. LEDP1Blk 6. P1Run 7. ComAlr 8. Buzz 9. - 10- 11P1Thermo 12P1Auto 13- 14P1Hand 15- 16- 	0000 0000 0000 0000	0000 0000 0000 0000	0000 0000 0000 0000

Menu number	Menu name	Description	Default settings		
			Compit analogue	Level regulator	NL analogue
20_3	Invert port C, D	Inversion of digital inputs and outputs for port C and D <ul style="list-style-type: none"> • 0 = No inversion • 1= Inversion In write mode, the names of the digital inputs are shown . Position: <ol style="list-style-type: none"> 1. - 2. P2Thermo 3. LEDP2Blk 4. LEDP2Err 5. - 6. P2Auto 7. P2Hand 8. StartSens2 9. PowFail 10Reset 11DigHiLev 12- 13- 14StartSens 15StopSens 16ExtAlr 	0000 0000 0000 0000	0000 0000 0000 0000	0000 0000 0000 0000
20_4	Diagnos. program	Diagnostic programs 1–39 are used for production test of the pump controller. <ul style="list-style-type: none"> • Off • 1 - 39 	Off	Off	Off
20_5	Set default val.	Restores all parameter values to the default values Operating data and the language setting are not affected. <ul style="list-style-type: none"> • No • Compit analogue • Level regulator • NL analogue 	No	No	No

12.10 Alarm descriptions

The blocking of the pump can be configured in two cases:





- High temperature alarm
- Maximum allowed run time alarm

Text in alarm log	Cause of the alarm	LED indication	Pump is blocked	With a communication module			
				Text in SCADA system	Alarm code	German default priority	Flygt default priority
High level	The level sensor detects a high level in pump sump.	High level	No	Analogue high level	1	A	B
Mains error	The main power is disrupted, or the phase sequence is incorrect, or one phase is missing.	Phase fail	Yes	Mains error	3	A	A

Text in alarm log	Cause of the alarm	LED indication	Pump is blocked	With a communication module			
				Text in SCADA system	Alarm code	German default priority	Flygt default priority
Hi.lev.float	The level in the pump sump reaches the high level switch. The pumps start.	High level	No	High level float	4	A	B
Pers. alarm	Immediate action is necessary to prevent imminent danger to the personnel. This alarm is always transmitted independently of the alarm status.	—	No	Personal alarm	5	A	A
External	Alarm from an external device that is connected to the RTU.	—	No	External alarm	7	B	B
P1 tripped	The overcurrent protection for Pump 1 has tripped. This alarm blocks the pump.	Pump failure	Yes	Tripped motor protector P1	11	A	B
P2 tripped	The overcurrent protection for Pump 2 has tripped. This alarm blocks the pump.	Pump failure	Yes	Tripped motor protector P2	12	A	B
P1 no resp.	There is no response signal from pump 1. The pump has not started despite activation of the power relay.	—	No	Operation error P1	30	C	B
P2 no resp.	There is no response signal from pump 2. The pump has not started despite activation of the power relay.	—	No	Operation error P2	31	C	B
Overflow	The pumping station overflows.	—	No	Overflow	34	A	A
P1 high temp	The temperature is high in pump 1.	Pump failure	Yes or No	High temperature P1	35	A	B
P2 high temp	The temperature is high in pump 2.	Pump failure	Yes or No	High temperature P2	36	A	B
Inval. setp.	The level setpoints are incorrect. The specified setpoints for start, stop, or high level are outside the calibration range, or they are mutually incorrect. For example, the high level setpoint is lower than the start level setpoint.	—	No	Missing parameters	8019	C	C
P1 max. run	The pump 1 has exceeded the maximum allowed run time.	Pump failure	Yes or No	P1 max run time	8484	B	B
P2 max. run	The pump 2 has exceeded the maximum allowed run time.	Pump failure	Yes or No	P2 max run time	8485	B	B
Sensor Fault	An error in the analogue sensor is detected. The measured level is outside the sensor range.	—	No	Sensor Fault	8505	C	B
Service P1	Pump 1 has reached the service interval time that has been entered. The pump needs service.	—	No	Service P1	8508	B	B
Service P2	Pump 2 has reached the service interval time that has been entered. The pump needs service.	—	No	Service P2	8509	B	B
Testcall!	A test alarm is sent to make sure that the RTU and its communication work correctly. The alarm is sent at a configurable interval.	—	No	Testcall!	8630	A	A

12.11 LED descriptions

Front panel

LED	LED color	Cause
	Green	The power supply is on.
	Not lit	The power supply is off, or a fuse is blown.
	Red	<p>The level in the pump sump is high.</p> <ul style="list-style-type: none"> The level exceeds the high level switch. Depending on the configuration, the pump controller starts one or both pumps. For more information, see Configure the high level switch on page 20. The level exceeds the configured high level limit when a level sensor is used. For more information, see Configure the start, stop, and high levels on page 19.
	Green	The pump runs.
	Red	The pump is stopped and restart is blocked. For more information, see Control a pump manually on page 26.
	Red that flashes	<ul style="list-style-type: none"> The incoming phases are connected in the wrong sequence, or a phase is missing. The power-on delay is working.
	Red	<p>There is a pump failure.</p> <ul style="list-style-type: none"> The temperature in the motor is too high. The current exceeds the configured maximum. For more information, see Configure the maximum motor current on page 19. The pump has run longer than the configured maximum time. For more information, see Configure the maximum runtime for a pump on page 21.

Main board

LED	LED color	Cause
Phase fail	Red	The incoming phases are connected in the wrong sequence, or a phase is missing.
Pwr ON	Green	The power supply is on.
High level	Red	<p>The level in the pump sump is high.</p> <ul style="list-style-type: none"> The level exceeds the high level switch. Depending on the configuration, the pump controller starts one or both pumps. . For more information, see Configure the high level switch on page 20. The level exceeds the configured high level limit when a level sensor is used. For more information, see Configure the start, stop, and high levels on page 19.
Running	Yellow	The pump runs.
Blocked	Red	The pump is stopped and restart is blocked. For more information, see Control a pump manually on page 26.
Failure	Red	<p>There is a pump failure.</p> <ul style="list-style-type: none"> The temperature in the motor is too high. The current exceeds the configured maximum. For more information, see Configure the maximum motor current on page 19. The pump has run longer than the configured maximum time. For more information, see Configure the maximum runtime for a pump on page 21.

Xylem |'zīləm|

- 1) The tissue in plants that brings water upward from the roots;
- 2) a leading global water technology company.

We're a global team unified in a common purpose: creating advanced technology solutions to the world's water challenges. Developing new technologies that will improve the way water is used, conserved, and re-used in the future is central to our work. Our products and services move, treat, analyze, monitor and return water to the environment, in public utility, industrial, residential and commercial building services settings. Xylem also provides a leading portfolio of smart metering, network technologies and advanced analytics solutions for water, electric and gas utilities. In more than 150 countries, we have strong, long-standing relationships with customers who know us for our powerful combination of leading product brands and applications expertise with a strong focus on developing comprehensive, sustainable solutions.

For more information on how Xylem can help you, go to www.xylem.com



Xylem Water Solutions Global
Services AB 556782-9253
361 80 Emmaboda
Sweden
Tel: +46-471-24 70 00
Fax: +46-471-24 74 01
<http://tpi.xylem.com>
[www.xylemwatersolutions.com/
contacts/](http://www.xylemwatersolutions.com/contacts/)

Visit our Web site for the latest version of this document and more information

The original instruction is in English. All non-English instructions are translations of the original instruction.

© 2016 Xylem Inc