

# FPG 415



---

# Table of Contents

<b>1 Introduction and Safety</b> .....	<b>3</b>
1.1 Introduction.....	3
1.2 Safety terminology and symbols.....	3
1.3 User safety.....	4
1.3.1 Power lock-out.....	5
1.3.2 Qualification of personnel.....	5
1.4 End-of-life product disposal.....	5
1.5 Spare parts.....	6
1.6 Warranty.....	6
1.7 Support.....	6
<b>2 System Description</b> .....	<b>7</b>
2.1 Adaptive mixers ADF.....	7
2.2 Adaptive mixers ADC.....	8
2.3 Adaptive ultra-low head propeller pumps ADF.....	10
2.4 Adaptive ultra-low head propeller pumps ADC.....	12
<b>3 Product Description</b> .....	<b>14</b>
3.1 Product design.....	14
3.2 Approvals.....	14
3.3 Parts.....	14
3.4 The data plate.....	15
<b>4 Mechanical Installation</b> .....	<b>16</b>
4.1 Do not install in an explosive zone.....	16
4.2 Install the gateway, ADF.....	16
4.3 Install the gateway, ADC.....	16
<b>5 Electrical Installation</b> .....	<b>18</b>
5.1 Precautions.....	18
5.2 Cables.....	19
5.3 Connect the gateway.....	19
5.3.1 Connect a single unit.....	19
5.3.2 Connect multiple units.....	22
5.3.3 Set the switches.....	22
5.4 Connect the controller and the gateways.....	23
5.4.1 Connect the units.....	23
5.4.2 Set the switches.....	24
<b>6 Operation</b> .....	<b>25</b>
6.1 Startup and operation.....	25
6.2 LED indicators.....	25

- 7 Maintenance..... 28**
  - 7.1 Preventive maintenance..... 28
  - 7.2 Change the battery..... 28
  
- 8 Troubleshooting.....30**
  - 8.1 The unit does not work..... 30
  
- 9 Technical Reference.....31**
  - 9.1 Dimensions.....31
  - 9.2 Environmental requirements..... 31
  - 9.3 IP rating.....31
  - 9.4 Electrical data.....32
  - 9.5 RTC battery.....32
  - 9.6 Terminals..... 32

# 1 Introduction and Safety

## 1.1 Introduction

### Purpose of the manual

The purpose of this manual is to provide necessary information for installation, operation, and maintenance of the unit.

### Read and keep the manual

Save this manual for future reference, and keep it readily available at the location of the unit.



### CAUTION:

Read this manual carefully before installing and using the product. Improper use of the product can cause personal injury and damage to property, and may void the warranty.

The equipment, and its functioning, may be impaired if used in a manner not specified by the manufacturer.

### Intended use



### WARNING:

Operating, installing, or maintaining the unit in any way that is not covered in this manual could cause death, serious personal injury, or damage to the equipment and the surroundings. This includes any modification to the equipment or use of parts not provided by Xylem. If there is a question regarding the intended use of the equipment, please contact a Xylem representative before proceeding.

## 1.2 Safety terminology and symbols



### About safety messages

It is extremely important that you read, understand, and follow the safety messages and regulations carefully before handling the product. They are published to help prevent these hazards:

- Personal accidents and health problems
- Damage to the product and its surroundings
- Product malfunction



### Hazard levels

Hazard level	Indication
 <p><b>DANGER:</b></p>	<p>A hazardous situation which, if not avoided, will result in death or serious injury</p>

Hazard level	Indication
 <p><b>WARNING:</b></p>	A hazardous situation which, if not avoided, could result in death or serious injury
 <p><b>CAUTION:</b></p>	A hazardous situation which, if not avoided, could result in minor or moderate injury
<p><b>NOTICE:</b></p>	Notices are used when there is a risk of equipment damage or decreased performance, but not personal injury.

Special symbols

Some hazard categories have specific symbols, as shown in the following table.

Electrical hazard	Magnetic fields hazard
 <p><b>Electrical Hazard:</b></p>	 <p><b>CAUTION:</b></p>

### 1.3 User safety

Introduction

All government regulations, local health and safety directives must be observed.

Prevent danger due to electricity

All danger due to electricity must be avoided. Electrical connections must always be carried out in compliance with the following:

- The standard connections shown in the product documentation that is delivered together with the product
- All international, national, state, and local regulations. (For details, consult the regulations of your local electricity supplier.)

For more information about requirements, see sections dealing specifically with electrical connections.

### 1.3.1 Power lock-out



#### DANGER: Electrical Hazard

Before starting work on the unit, make sure that the unit and the control panel are isolated from the power supply and cannot be energized. This applies to the control circuit as well.



### 1.3.2 Qualification of personnel



#### WARNING: Electrical Hazard

Risk of electrical shock or burn. A certified electrician must supervise all electrical work. Comply with all local codes and regulations.

All work on the product must be carried out by certified electricians or Xylem authorized mechanics.

Xylem disclaims all responsibility for work done by untrained, unauthorized personnel.

## 1.4 End-of-life product disposal

Handle and dispose of all waste in compliance with local laws and regulations.

EU and UK only: Correct disposal of this product – waste electrical and electronic equipment

- EU: Directive 2012/19/EU on waste electrical and electronic equipment (WEEE)
- UK: SI 2013 No. 3113

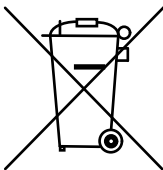

WS0009973A

This marking on the product, accessories, or literature shows that the product should not be disposed of with other waste at the end of its working life.

To prevent possible harm to the environment or human health from uncontrolled waste disposal, please separate these items from other types of waste and recycle them responsibly to promote the sustainable reuse of material resources.

Waste from electrical and electronic equipment can be returned to the producer or distributor.

**EU and UK only: Correct disposal of batteries in this product**

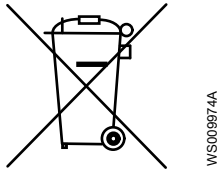

This marking on the battery, manual, or packaging shows that the batteries in this product should not be disposed of with other waste at the end of its working life. Where marked, the chemical symbols Hg, Cd, or Pb indicate that the battery contains mercury, cadmium, or lead above the reference levels in 2006/66/EC or UK SI 2008 No. 2164. If batteries are not properly disposed of, these substances can cause harm to human health or the environment.

To protect natural resources and to promote material reuse, please separate batteries from other types of waste and recycle them through your local, free battery return system.

### 1.5 Spare parts

---



#### **CAUTION:**

Only use the manufacturer's original spare parts to replace any worn or faulty components. The use of unsuitable spare parts may cause malfunctions, damage, and injuries as well as void the warranty.

---

### 1.6 Warranty

For information about warranty, see the sales contract.

### 1.7 Support

Xylem only supports products that have been tested and approved. Xylem does not support unapproved equipment.

# 2 System Description

## 2.1 Adaptive mixers ADF

The mixer is connected to an FPG 415 gateway that has an embedded web server. The operator connects to the web server through the HMI.

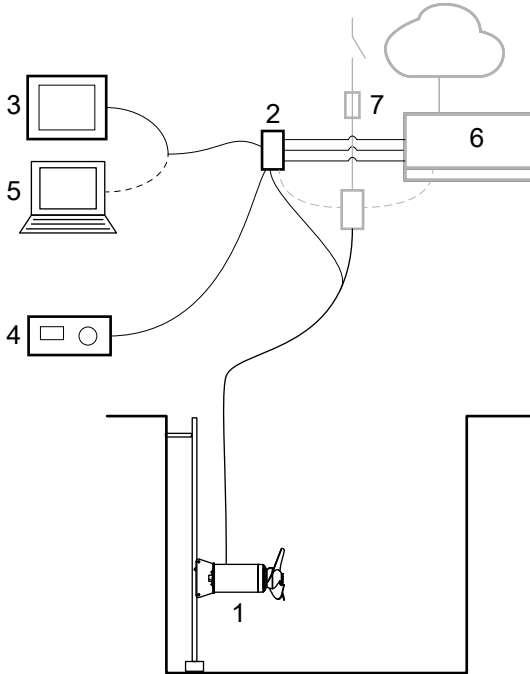

WS010433B

### Parts

Number	Part	Product name	Description
1	Mixer	<ul style="list-style-type: none"> <li>SR 4220</li> <li>SR 4230</li> <li>SR 4320</li> </ul>	A mixer with an integrated intelligent technology

Number	Part	Product name	Description
2	Gateway	FPG 415	<ul style="list-style-type: none"> <li>• A gateway with an embedded web server.                             <ul style="list-style-type: none"> <li>- Digital input signal</li> <li>- Analog input signal</li> <li>- Modbus</li> </ul> </li> <li>• All the alarms are sent back to the external control system.</li> <li>• The operator changes the mixer settings through the gateway.</li> <li>• Data is logged by and stored in the gateway.</li> </ul>
3	HMI	FOP 402	HMI - Alternative 1 <ul style="list-style-type: none"> <li>• A touchscreen HMI that is used for navigation and selection in the menus.</li> <li>• The touchscreen HMI is connected to a web server that is embedded in the gateway.</li> </ul>
4	HMI	FOP 315	HMI - Alternative 2 <ul style="list-style-type: none"> <li>• A basic HMI with a jog wheel that is used for navigation and selection in the menus.</li> </ul>
5	Computer	-	HMI - Alternative 3 <ul style="list-style-type: none"> <li>• The computer gives access to the same menu system as the touchscreen HMI.</li> <li>• The computer is connected to a web server that is embedded in the gateway.</li> </ul>
6	Connectivity options	-	<ul style="list-style-type: none"> <li>• Controller / RTU / PLC</li> <li>• Cloud services</li> <li>• Mixer sum-alarm I/O</li> </ul>
7	Connection to power	-	Contactors, fuses, relays

## 2.2 Adaptive mixers ADC

The system consists of one to eight mixers, with one APP 412 controller and one FPG 415 gateway for each additional mixer.

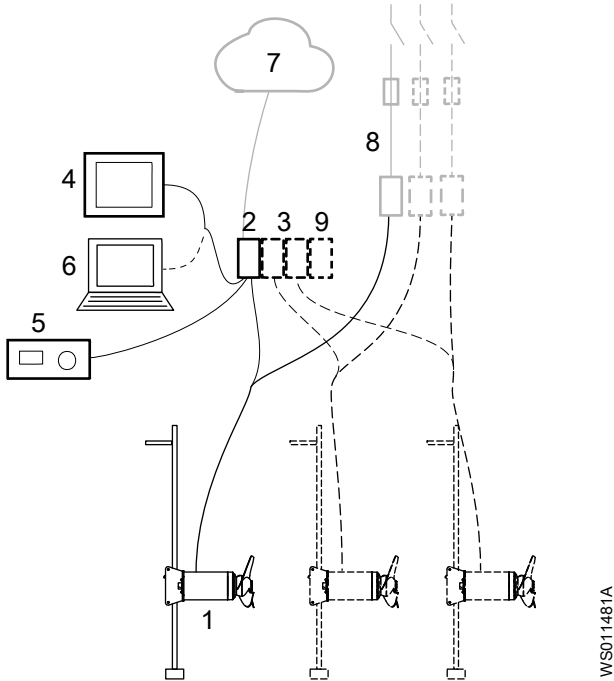

Parts

Number	Part	Product name	Description
1	Mixer	<ul style="list-style-type: none"> <li>• SR 4220</li> <li>• SR 4230</li> <li>• SR 4320</li> </ul>	A mixer with an integrated intelligent technology
2	Controller	APP 412	<ul style="list-style-type: none"> <li>• Based on process conditions, the controller regulates the mixer.</li> <li>• The operator changes the mixer settings through the local HMI or through a SCADA system over Modbus.</li> <li>• Data is logged by and stored in the controller.</li> <li>• All the alarms are available on the local HMI and Modbus.</li> <li>• System communication through the backplane.</li> </ul>
3	Gateway	FPG 415	<p>A gateway that is controlled by APP 412</p> <ul style="list-style-type: none"> <li>• System communication through the backplane.</li> <li>• All the alarms and data are sent to the controller.</li> </ul>

Number	Part	Product name	Description
4	HMI	FOP 402	HMI - Alternative 1 <ul style="list-style-type: none"><li>• A touchscreen HMI that is used for navigation and selection in the menus.</li><li>• The touchscreen HMI is connected to a web server that is embedded in the controller.</li></ul>
5	HMI	FOP 315	HMI - Alternative 2 <ul style="list-style-type: none"><li>• A basic HMI with a jog wheel that is used for navigation and selection in the menus.</li></ul>
6	Computer	-	HMI - Alternative 3 <ul style="list-style-type: none"><li>• The computer gives access to the same menu system as the touchscreen HMI.</li><li>• The computer is connected to a web server that is embedded in the controller.</li></ul>
7	Cloud connection	-	Cloud services
8	Connection to power	-	Contactors, fuses, relays
9	Extended I/O module	FPG 415	A gateway that is used as an extended I/O module

### 2.3 Adaptive ultra-low head propeller pumps ADF

The pump is connected to an FPG 415 gateway that has an embedded web server. The operator connects to the web server through the HMI.

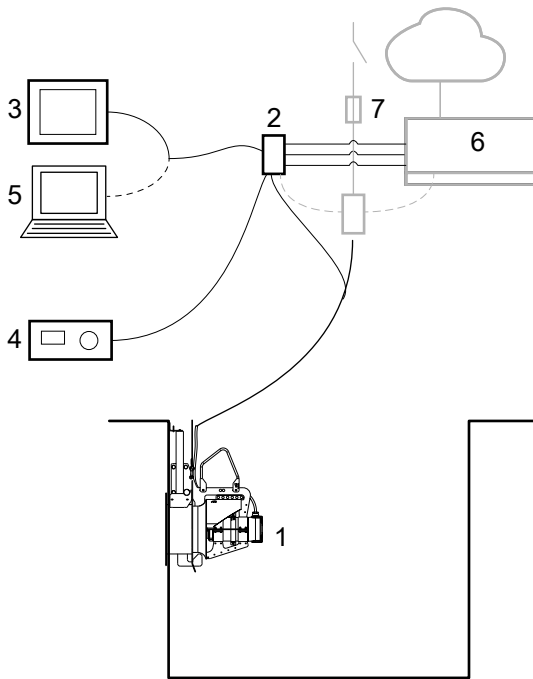

WSO10857B

## Parts

Number	Part	Product name	Description
1	Pump	<ul style="list-style-type: none"> <li>PP 4220</li> <li>PP 4230</li> </ul>	A pump with an integrated intelligent technology
2	Gateway	FPG 415	<ul style="list-style-type: none"> <li>A gateway with an embedded web server. <ul style="list-style-type: none"> <li>Digital input signal</li> <li>Analog input signal</li> <li>Modbus</li> </ul> </li> <li>All the alarms are sent back to the external control system.</li> <li>The operator changes the pump settings through the gateway.</li> <li>Data is logged by and stored in the gateway.</li> </ul>
3	HMI	FOP 402	HMI - Alternative 1 <ul style="list-style-type: none"> <li>A touchscreen HMI that is used for navigation and selection in the menus.</li> <li>The touchscreen HMI is connected to a web server that is embedded in the gateway.</li> </ul>

Number	Part	Product name	Description
4	HMI	FOP 315	HMI - Alternative 2 <ul style="list-style-type: none"> <li>• A basic HMI with a jog wheel that is used for navigation and selection in the menus.</li> </ul>
5	Computer	-	HMI - Alternative 3 <ul style="list-style-type: none"> <li>• The computer gives access to the same menu system as the touchscreen HMI.</li> <li>• The computer is connected to a web server that is embedded in the gateway.</li> </ul>
6	Connectivity options	-	<ul style="list-style-type: none"> <li>• Controller / RTU / PLC</li> <li>• Cloud services</li> <li>• Pump sum-alarm I/O</li> </ul>
7	Connection to power	-	Contactors, fuses, relays

## 2.4 Adaptive ultra-low head propeller pumps ADC

The system consists of one to eight pumps, with one APP 412 controller and one FPG 415 gateway for each additional pump.

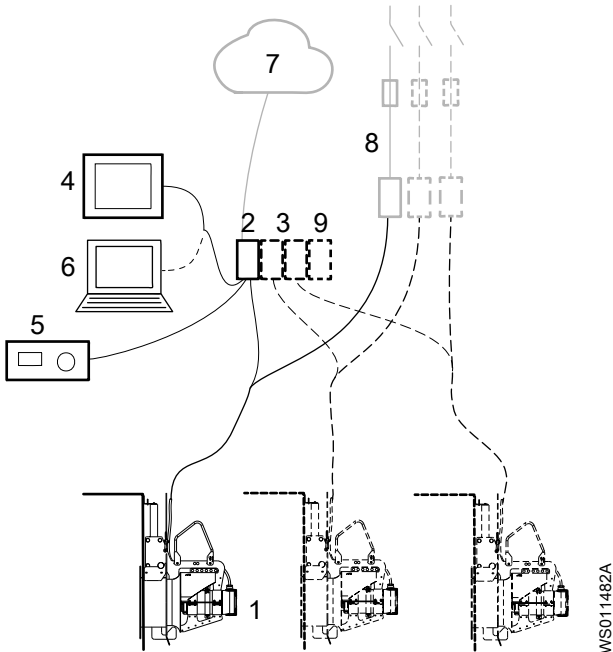

Parts

Number	Part	Product name	Description
1	Pump	<ul style="list-style-type: none"> <li>• PP 4220</li> <li>• PP 4230</li> </ul>	A pump with an integrated intelligent technology

Number	Part	Product name	Description
2	Controller	APP 412	<ul style="list-style-type: none"> <li>• The controller starts and stops the pump based on input signals.</li> <li>• The operator changes the pump settings through the local HMI or through a SCADA system over Modbus.</li> <li>• Data is logged by and stored in the controller.</li> <li>• All the alarms are available on the local HMI and Modbus.</li> <li>• System communication through the backplane.</li> </ul>
3	Gateway	FPG 415	<p>A gateway that is controlled by APP 412</p> <ul style="list-style-type: none"> <li>• System communication through the backplane.</li> <li>• All the alarms and data are sent to the controller.</li> </ul>
4	HMI	FOP 402	<p>HMI - Alternative 1</p> <ul style="list-style-type: none"> <li>• A touchscreen HMI that is used for navigation and selection in the menus.</li> <li>• The touchscreen HMI is connected to a web server that is embedded in the controller.</li> </ul>
5	HMI	FOP 315	<p>HMI - Alternative 2</p> <ul style="list-style-type: none"> <li>• A basic HMI with a jog wheel that is used for navigation and selection in the menus.</li> </ul>
6	Computer	-	<p>HMI - Alternative 3</p> <ul style="list-style-type: none"> <li>• The computer gives access to the same menu system as the touchscreen HMI.</li> <li>• The computer is connected to a web server that is embedded in the controller.</li> </ul>
7	Cloud connection	-	Cloud services
8	Connection to power	-	Contactors, fuses, relays
9	Extended I/O module	FPG 415	A gateway that is used as an extended I/O module

# 3 Product Description

## 3.1 Product design

FPG 415 is a gateway that is connected to Flygt adaptive mixers or to Flygt adaptive ultra low head pumps. The gateway starts and stops the mixer or the pump based on the input signal from the external control system. All the alarms are sent back to the external control system. Data is logged by and stored in the gateway.

Product name	Part number	Description
FPG 415	8202800	Gateway for Flygt adaptive mixers or Flygt adaptive ultra low head pumps Dynamic mixer/pump performance change, through 4-20 mA or Modbus.

## 3.2 Approvals

- CE
- UL
- CSA
- RCM

## 3.3 Parts

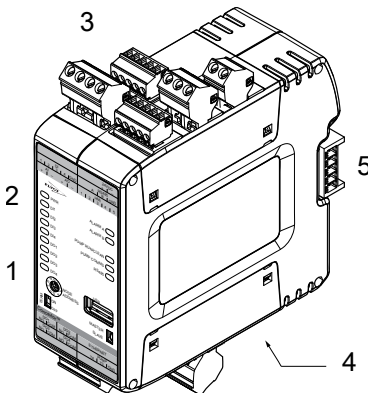

WS009747C

1. Front connections
2. Status LEDs
3. Top connections
4. Bottom connections
5. Backplane connector

### 3.4 The data plate

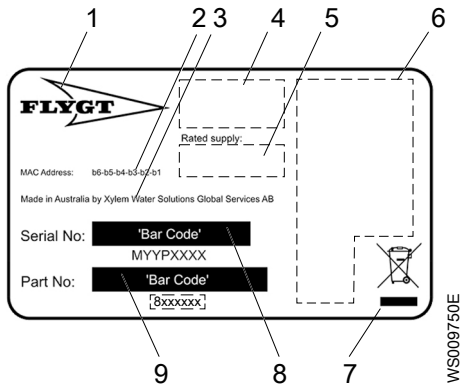

1. Brand
2. MAC address
3. Country of origin. Manufacturer.
4. Product
5. Rated supply
6. Approvals
7. Waste disposal symbol
8. Serial number
9. Part number

# 4 Mechanical Installation

## 4.1 Do not install in an explosive zone

---

**NOTICE:**

Do not use this unit in environments that may contain flammable/explosive or chemically aggressive gases or powders.

---

## 4.2 Install the gateway, ADF

Snap the unit onto the DIN rail.

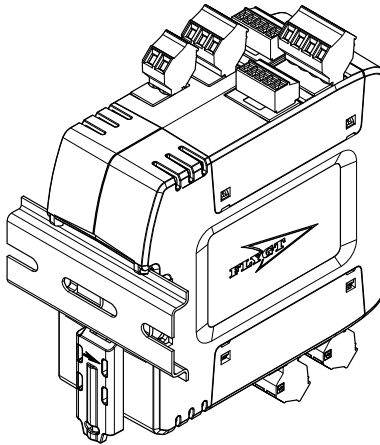

WS009751B

## 4.3 Install the gateway, ADC

1. Connect the backplane connectors.

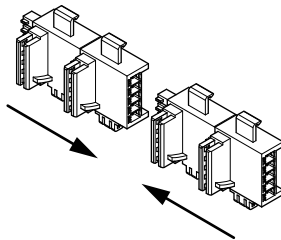

WS011301A

2. Install the backplane connectors on the DIN rail.

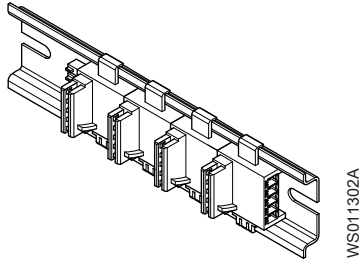

3. Snap the unit or units onto the DIN rail.

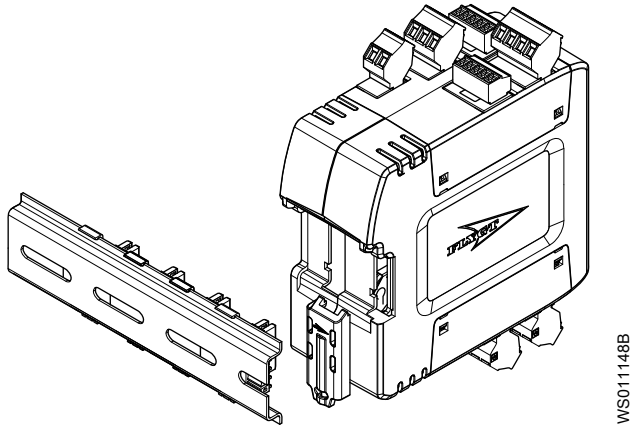

# 5 Electrical Installation

## 5.1 Precautions

Before starting work, make sure that the safety instructions have been read and understood.

---



### **DANGER: Electrical Hazard**

Before starting work on the unit, make sure that the unit and the control panel are isolated from the power supply and cannot be energized. This applies to the control circuit as well.



### **DANGER: Electrical Hazard**

All electrical equipment must be grounded (earthed). Test the ground (earth) lead to verify that it is connected correctly and that the path to ground is continuous.

---

---



### **WARNING: Electrical Hazard**

Risk of electrical shock or burn. A certified electrician must supervise all electrical work. Comply with all local codes and regulations.

---

---



### **WARNING: Electrical Hazard**

There is a risk of electrical shock or explosion if the electrical connections are not correctly carried out, or if there is fault or damage on the product. Visually inspect equipment for damaged cables, cracked casings or other signs of damage. Make sure that electrical connections have been correctly made.

---

---



### **CAUTION: Electrical Hazard**

Prevent cables from becoming sharply bent or damaged.

---

## Requirements

These requirements apply for electrical installation:

- All fuses and circuit breakers must have the proper rating, and comply with local regulations.
- The cables must be in accordance with the local rules and regulations.

## 5.2 Cables

These requirements apply for power and Ethernet cable installation:

- The cables must be in good condition, not have any sharp bends, and not be pinched.
- The sheathing must not be damaged and must not have indentations or be embossed at the cable entry.
- The minimum bending radius must not be below the accepted value.
- The cables must have the appropriate temperature rating.

## 5.3 Connect the gateway

The gateway is installed with an external control system. For more information, see [System Description](#) on page 7.

Some of the connection terminals are configurable. For more information, see the System Installation and Operation Manual.

### 5.3.1 Connect a single unit

This instruction describes all connection possibilities. Some of them are optional. Connect only one HMI.

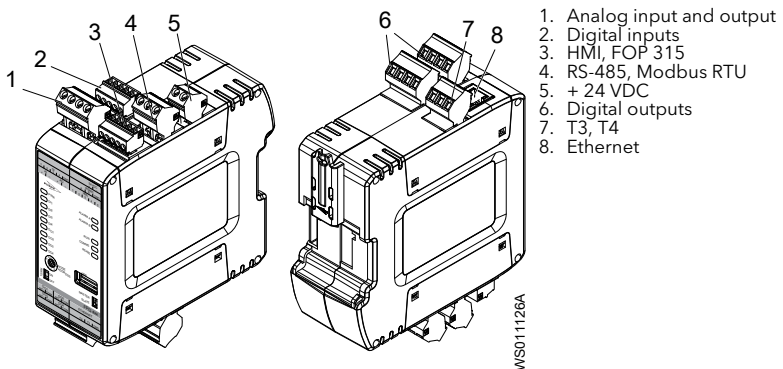

#### Mixer or pump

1. Connect the T3 and T4 cables from the mixer or the pump to the T3, T4 terminal.

Create as much separation as possible between the power cores and the control cables. Keep the T3 and T4 cables twisted and shielded as close to the terminals as possible.

Ethernet

2. Connect the Ethernet cable to the Ethernet terminal.

It is possible to use the Ethernet terminal for multiple communication options:

- Communication with FOP 402
- Communication with SCADA systems through Modbus TCP

If the Ethernet terminal is used for multiple communication options, then use an Ethernet switch.

- The Ethernet cable must fulfill category 5.
- For more information about the Modbus interface, see separate documentation.

FOP 315 HMI

3. Connect the FOP 315 cable to the HMI terminal.

The maximum cable length is 100 m (328 ft).

Description	HMI cable	Cable color	HMI terminal on the gateway
Ground	GND	Black	1
CAN low	L	Blue	2
Shield	-	Transparent	3
CAN high	H	White	4
Power	+24 V	Red	5

Modbus RTU

4. Connect the Modbus RTU cable to the RS-485 terminal.

Analog input

5. Connect the analog input cables to the analog input terminal.

The analog input is passive. The external circuit needs an external power source.

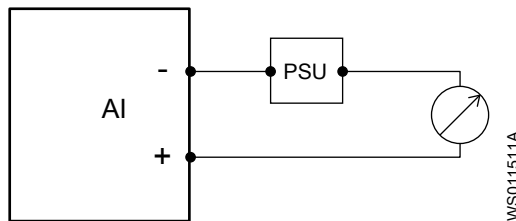

Signal	Description
4 mA	Minimum input
20 mA	Maximum input

Digital inputs

6. Connect the digital input cables to the digital input terminal.

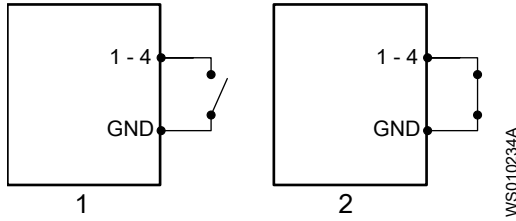

- 1. Open
- 2. Closed

Digital outputs

- 7. Connect the digital output cables to the digital output terminals.  
 The digital outputs are potential free relay outputs. Connect a power supply unit maximum 250 VAC, or 30 VDC, 5 A.  
 The digital outputs are configurable to be normally open or normally closed.

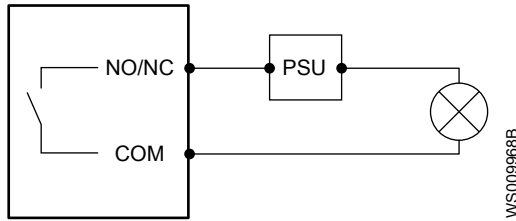

Analog output

- 8. Connect the analog output cables to the analog output terminal.  
 The analog output is active. The external circuit does not need an external power source.

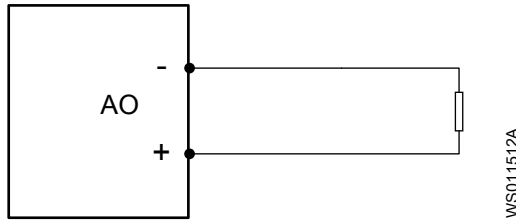

Signal	Description
4 mA	Minimum level
20 mA	Maximum level

Power

- 9. Connect the power cables to the + 24 VDC terminal.  
 The power supply unit must fulfill isolation class II.

### 5.3.2 Connect multiple units

When multiple units are installed in the same application, cables are connected in parallel or separately.

The backplane connectors are not used when the installation includes gateways only.

Connect only one HMI.

1. Connect the FOP 315 HMI cables in parallel.

Terminate with a 120 ohm resistor between terminals 2 and 4 at the end that is farthest from the HMI. The maximum cable length is 100 m (328 ft).

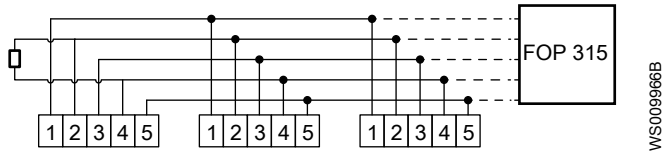

2. Connect the start signal cables separately.
3. Connect the Modbus cable in parallel.
4. Connect the Ethernet cable through a switch to each gateway.
5. Connect the power cable separately or in parallel.
6. Connect each analog input signal cable separately.

### 5.3.3 Set the switches

Set the switches.

Switch	Correct setting
NODE ADDRESS, 0-9	All the node addresses in the system must be unique and not 0.
MASTER/SLAVE	MASTER
TERM, ON/OFF	ON

The groove is perpendicular to the arrow in the node address setting. This image shows node address 1.

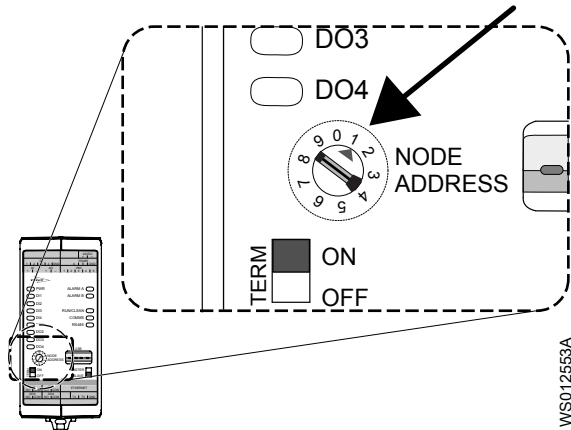

## 5.4 Connect the controller and the gateways

Some of the connection terminals are configurable. For more information, see the System Installation and Operation Manual.

### 5.4.1 Connect the units

When multiple units are installed in the same application, cables are connected in parallel or separately.

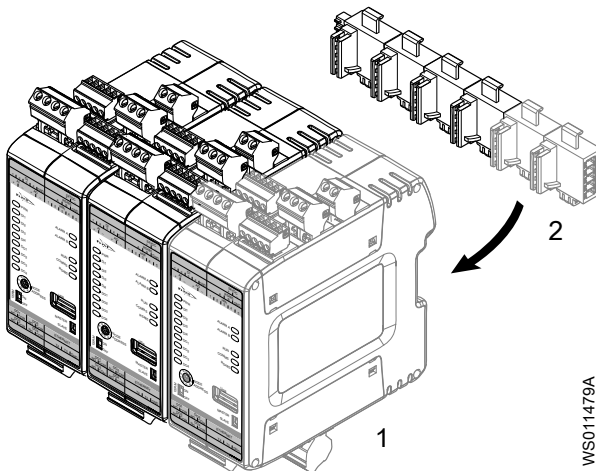

1. Gateways, controller
2. Backplanes

1. Make sure that the backplanes are connected.
2. Connect the cables for the applicable equipment to all units.
3. Connect the power cables to the + 24 VDC terminal of each gateway or controller.

### 5.4.2 Set the switches

Set the switches.

Switch	Correct setting
NODE ADDRESS, 0-9	All the node addresses in the system must be unique and not 0.
MASTER/SLAVE	<ul style="list-style-type: none"> <li>- APP 412: MASTER</li> <li>- FPG 415: SLAVE</li> </ul>
TERM, ON/OFF	<ul style="list-style-type: none"> <li>- Set the termination switch of the first and the last unit in the chain to <b>ON</b>.</li> <li>- Set the termination switches of the other units in the system to <b>OFF</b>.</li> </ul>

The groove is perpendicular to the arrow in the node address setting. This image shows node address 1.

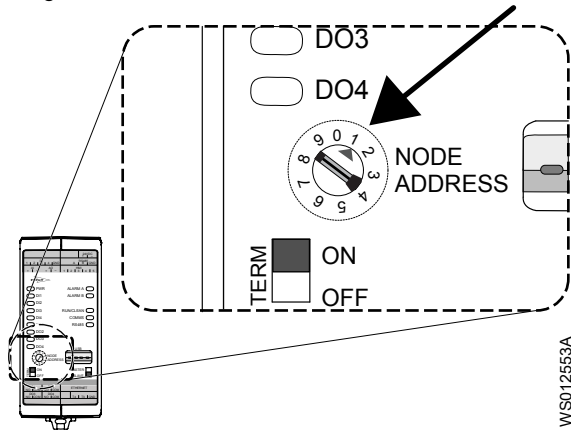

# 6 Operation

## 6.1 Startup and operation

For instructions about the system operation, see the System Installation and Operation manual.

## 6.2 LED indicators

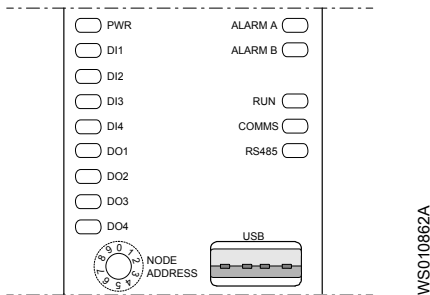

Table 1: Normal operation

LED	Description	Color	Indication
PWR	Power	Green	The power is on. 21.6-26.4 V
		-	The power is off.
		Orange	20.0-21.6 V 26.4-29.4 V
		Red	<20.0 V >29.4 V
DI1 - DI4	Digital inputs	Green	The digital input is active.
		-	The digital input does not receive a signal.
DO1 - DO4	Digital outputs	Green	The digital output is active.
		-	The digital output is inactive.
ALARM A	Alarm, Class A	Flashing red	The alarm is not acknowledged. The alarm condition is either present or has ceased.

LED	Description	Color	Indication
		Constant red	The alarm condition is present. The alarm is acknowledged, or no acknowledgement is required.
		-	There is no alarm.
ALARM B	Alarm, Class B	Flashing red	The alarm is not acknowledged. The alarm condition is either present or has ceased.
		Constant red	The alarm condition is present. The alarm is acknowledged, or no acknowledgement is required.
		-	There is no alarm.
RUN	Mixer/pump running	Green	The mixer/pump is operating.
		-	The mixer/pump is not operating.
COMMS	Mixer/pump communication	Green	The mixer/pump communication is established.
		-	No mixer/pump communication is established.
RS-485	Modbus RTU communication	Green	Modbus RTU communication
		-	No Modbus RTU communication

Table 2: Fault indications

ALARM A	ALARM B	RUN	COMMS	RS-485	Indication
Flashing red	-	-	-	Flashing green	The unit is defective. Contact the local sales and service representative.
Flashing red	Flashing red	Flashing orange	Flashing green	Flashing green	Software fault. Restart the unit.

---

<b>ALARM A</b>	<b>ALARM B</b>	<b>RUN</b>	<b>COMMS</b>	<b>RS-485</b>	<b>Indication</b>
Flashing red	Flashing red	-	-	-	The communication between the controller and the gateways in the system is lost. The gateways are operating in redundancy mode.

# 7 Maintenance

## 7.1 Preventive maintenance



### DANGER: Crush Hazard

Moving parts can entangle or crush. Always disconnect and lock out power before servicing to prevent unexpected startup. Failure to do so could result in death or serious injury.



---

Make sure that the unit is clean from dust and dirt. Use a wet cloth and soapy water for cleaning.

## 7.2 Change the battery

1. Turn off the power to the system.
2. If applicable, then remove the unit from the backplane.
3. Remove the battery lid.

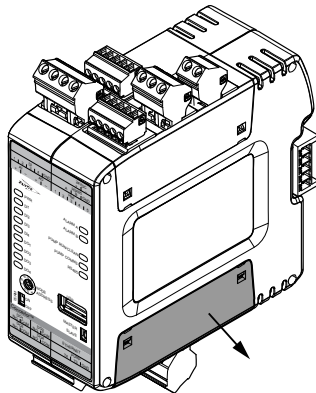

WS014090A

4. Change the battery.  
For more information about the battery type, see [RTC battery](#) on page 32.
5. Attach the battery lid.
6. If applicable, then attach the unit to the backplane.

7. Turn on the power to the system.
8. Make sure that the real-time clock (RTC) shows the correct time.

# 8 Troubleshooting

## 8.1 The unit does not work

Make sure that all wires are correctly connected according to the cable chart.

Cause	Remedy
The PWR LED is not lit.	<ul style="list-style-type: none"><li>• Make sure that the unit receives voltage.</li><li>• Restart the unit.</li></ul>
The unit does not communicate with the mixer/pump.	<ul style="list-style-type: none"><li>• Make sure that the mixer/pump receives voltage.</li><li>• Restart the mixer/pump and the unit.</li></ul>

If the problem persists, then contact a sales or authorized service representative.

Always state the product number and the serial number of the product.

# 9 Technical Reference

## 9.1 Dimensions

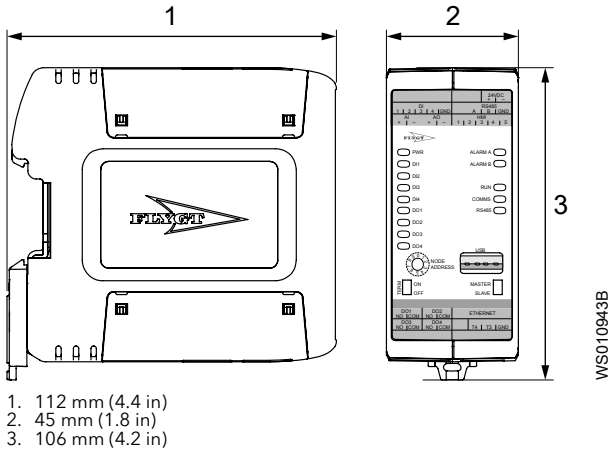

## 9.2 Environmental requirements

Parameter	Value
Operating temperature	-20°C - +65°C (-4°F - 149°F)
Storage temperature	-20°C - +70°C (-4°F - 158°F)
Operating humidity	Relative humidity, maximum 90%
Sunlight exposure	UV-resistant
Maximum altitude	<ul style="list-style-type: none"> <li>• With UL approval: Maximum 2000 m (6562 ft)</li> <li>• Without UL approval: 4000 m (13 123 ft)</li> </ul>
Pollution degree	2
Installation location	Indoors Not intended for use in wet locations
Overvoltage category	II

## 9.3 IP rating

IPXY  
| |  
1 23

1. Ingress Protection Code (IP)
2. Degree of protection against foreign objects
3. Degree of protection against water

Degree of protection, IP20

Code	Description
2	The enclosure is protected against: <ul style="list-style-type: none"> <li>• Fingers or objects that are less than 80 mm (3.15 in) in length</li> <li>• Objects that are larger than 12.5 mm (0.49 in) in diameter</li> </ul>
0	The enclosure is not protected against water.

### 9.4 Electrical data

Parameter	Value
Supply voltage	+ 24 VDC
Supply voltage tolerance	21.5-28.5 VDC
Current consumption	< 700 mA. Typical: 150 mA

### 9.5 RTC battery

The gateway has an internal battery for the real-time clock (RTC).

Parameter	Value
Battery type	BR1632 CR1632
Nominal battery voltage	3 V
Battery capacity	120 mAh

### 9.6 Terminals

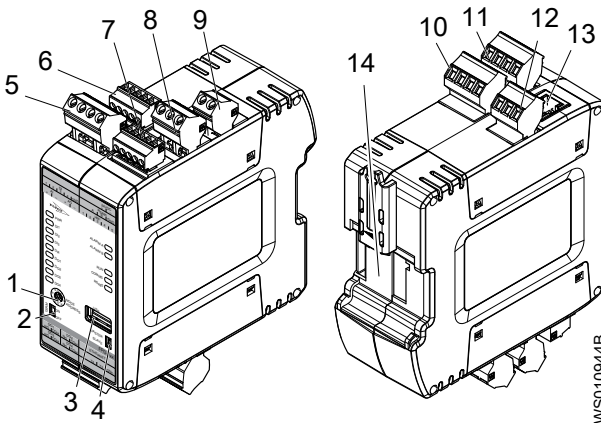

Section	Terminal	Description
1	NODE ADDRESS	Node address 0-9, rotary switch. 0 is not used.

Section	Terminal		Description	
2	TERM		Backplane termination switch	
3	USB		Standard type A USB socket	
4	MASTER, SLAVE		MASTER/SLAVE switch	
5	AI	+	Isolated analog input, 4–20 mA Maximum 24 VDC Scaling: 0–100% Offset: 0–16 mA with 0.1 mA resolution	
		–		
	AO	+		Analog output, 4–20 mA
		–		Maximum 24 VDC
6	DI	1	Digital inputs	
		2	Maximum 24 VDC	
		3		
		4		
		GND		Common ground (earth)
7	HMI • Flygt FOP 315	1	Ground	
		2	CAN low	
		3	Shield	
		4	CAN high	
		5	+ 24 VDC output	
8	RS-485	A	Modbus RTU	
		B		
		GND		
9	24 VDC	+	24 VDC Tolerance: 21.5–28.5 VDC The power supply unit must fulfill isolation class II. < 700 mA. Typical: 150 mA Fuse: 1 A	
		–		
10	DO3	NO	Digital outputs	
		COM	Potential free relay output	
	DO4	NO	Maximum 250 VAC, or 30 VDC, 5 A External fuse required, 5 A	
		COM		
11	DO1	NO		
		COM		
	DO2	NO		
		COM		
12	–	T4	Mixer/pump communication	
		T3		
		GND	Not used	

<b>Section</b>	<b>Terminal</b>	<b>Description</b>
13	Ethernet	<ul style="list-style-type: none"><li>• Modbus TCP</li><li>• Web server</li></ul>
14	Backplane	The Flygt controller communicates with the Flygt gateways through the backplane.







# Xylem |'zīləm|

- 1) The tissue in plants that brings water upward from the roots;
- 2) a leading global water technology company.

We're a global team unified in a common purpose: creating advanced technology solutions to the world's water challenges. Developing new technologies that will improve the way water is used, conserved, and re-used in the future is central to our work. Our products and services move, treat, analyze, monitor and return water to the environment, in public utility, industrial, residential and commercial building services settings. Xylem also provides a leading portfolio of smart metering, network technologies and advanced analytics solutions for water, electric and gas utilities. In more than 150 countries, we have strong, long-standing relationships with customers who know us for our powerful combination of leading product brands and applications expertise with a strong focus on developing comprehensive, sustainable solutions.

For more information on how Xylem can help you, go to [www.xylem.com](http://www.xylem.com)



Xylem Water Solutions Global  
Services AB 556782-9253  
361 80 Emmaboda  
Sweden  
Tel: +46-471-24 70 00  
Fax: +46-471-24 74 01  
<http://tpi.xyleminc.com>

Visit our Web site for the latest version of this document and more information

The original instruction is in English. All non-English instructions are translations of the original instruction.

© 2018 Xylem Inc